

Peter Meyer

Ball valves

Cryogenic

Features

- Swiss manufacturer
- One-piece body design
- Laser welded, without body seal
- Full bore
- Chambered seats
- Cryogenic extension
- Cavity pressure relief system
- Replaceable packing in depressurized, built-in condition
- Anti blow-out stem
- Low cavity behind the seats
- Antistatic device
- Smart construction shape, minimum weight and good accessibility
- Fire Safe Design
- All valves comply to PED 2014/68/EU
- SVGW approved
- All valves are in compliance with TA-Luft
- ATEX certification acc. directive 2014/34/EU
- Tightness test acc. to EN 12266-1, rate A

Technical data

Sizes (mm):	DN 10 – DN 150
Pressure class:	PN 10 – 40 or ANSI Class 150/300 lbs (other pressure classes on request)
Temperature range:	-200°C up to +200°C (in acc. to the ratings)
Connections:	Flanges acc. to EN 1092-1 Butt welding ends acc. to EN 12627 Threaded ends internal in acc. to DIN ISO 228-1 Threaded ends external in acc. to DIN ISO 228-1
Face-to-face:	Flanged in acc. to EN 558 and ANSI B16.10 Butt welding ends in acc. to EN 12982 R1 Threaded ends in acc. to DIN 3202 T4 M2
Top flange:	In acc. to DIN EN ISO 5211:2001

Options

- Pressure balancing hole in the ball
- Different connections and face-to-faces are available on request

General applications

The cryogenic ball valves are specially designed to be used in cryogenic process installations for very cold media such as liquefied gases CO₂, N₂, Ar, O₂, natural gas (LNG). The spring loaded seat system assures an easy operation of the ball down to a temperature of -200°C. The cryogenic extension guides the stem with the packing out of the icing area.



Pressure and Temperature Ratings for the seats

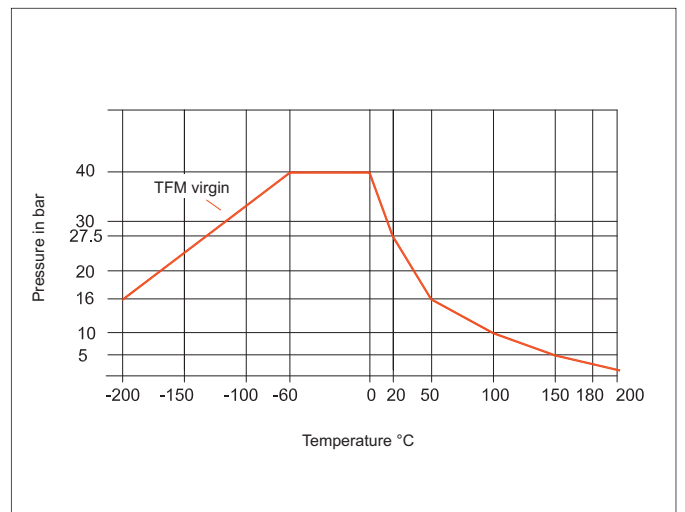

Depending on size and pressure rating

Flanged ball valves

Dimensions and weight

with wrench

DN	KB* Ø mm	PN	L acc. to EN 558		H1	H2	G	ISO 5211	Weight (kg)
			R1	R27					R1
10	14	40	130	110	47	410	120	F03	3.8
15	14	40	130	115	47	410	120	F03	3.8
20	20	40	150	120	53	415	120	F03	4.4
25	25	40	160	125	63	425	120	F04	5.6
32	32	40	180	130	71	432	120	F04	7.4
40	40	40	200	140	87	460	200	F05	9.1
50	50	40	230	150	96	470	200	F05	12.3
65	65	16/40	290	170	119	456	300*	F07	18.6
80	80	16/40	310	180	131	464	300*	F07	25.8
100	100	16/40	350	190	146	484	300*	F07	33
150	150	16/40	480 ¹⁾	350	221	580	550*	F12	89.5

*KB = Ball bore

1) on request 450 mm (R28)

*double wrench total length

Dimensions in mm

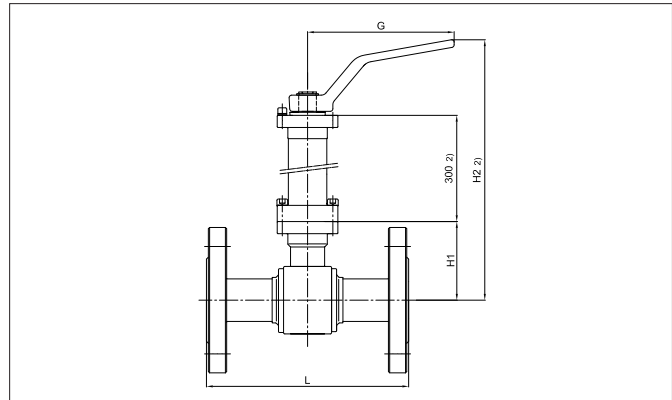

Flanges in acc. to EN 1092-1 Form B

2) other lengths on request

Parts list

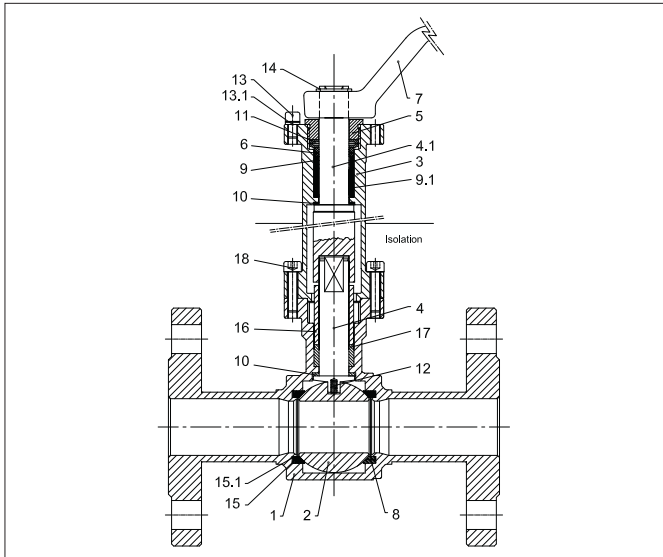

Item	Description	Material	Quantity
1	Body	1.4404	1
2	Ball	1.4408	1
3	Cryogenic extension/Gland	1.4404	1
4	Stem	1.4404	1
4.1	Stem of Cryogenic extension	1.4404	1
5	Gland cover	1.4305	1
6	Thrust ring	1.4305	1
7	Wrench	Anticorodal	1
8	Seat	TFM-Virgin	2
9	Stem packing	Graphite	1
9.1	Stem packing	PTFE	1
10	Slide ring	PTFE	2
11	Spring washer	1.4310	2
12	Antistatic spring	1.4401	1
13	Stop screw	1.4301	2
13.1	Washer	1.4301	6
14	Circlip ring	1.4034	1
15	Spring ring	Alloy718	1
15.1	Ground ring	PTFE	1
16	Spacer sleeve	1.4404	1
17	Stem bearing	PTFE	1
18	Screw	1.4301	4

Other body materials such as 1.4435, 1.4539, Hastelloy, Titan, Tantal, etc. on request.

Butt welding ends ball valves

DN	KB* Ø mm	PN	A	ØB	ØC	Weight. (kg)
10	14	40	130	17.2	14	2.6
15	14	40	130	21.3	18.1	2.6
20	20	40	150	26.9	23.7	2.9
25	25	40	160	33.7	29.7	3.5
32	32	40	180	42.4	38.4	4.3
40	40	40	200	48.3	44.3	5.6
50	50	40	230	60.3	56.3	7.5
65	65	16/40	290	76.1	71.5	12.6
80	80	16/40	310	88.9	84.3	17.1
100	100	16/40	350	114.3	109.1	24.7
150	150	16/40	480	168.3	163.1	66.5

*KB = Ball bore

Dimensions in mm

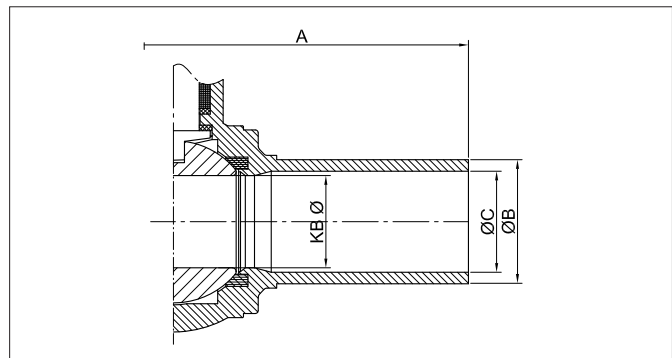

Face-to-face dimensions acc. to EN 12982 R1

Butt welding ends acc. to EN 12627

Subject to alterations



Stem seal

High sealing performance due to TA-Luft certified live loaded packing in combination with PTFE and graphite.



Cryogenic extension assembly

Save sealing function against outside due to metallic sealing to the body. Inside the accurate stem bearing in PTFE with spacer sleeve in stainless steel.



Seats

In TFM-Virgin provides positive shut-off, are unidirectional metallic spring loaded and equipped with the integrated cavity pressure relief system.

Integrated cavity pressure relief system

Features

- The system relieves the overpressure inside the ball (P_t) to the upstream pressure side P_1 independent of the flow direction. If the medium is able to freeze, the upstream pressure must be on spring side. The spring is always on the body welding side.
- The chambered seats remain always in contact with the ball. The system is relieving over channels between seat and body (no abrasion or dirt in the sealing surface of the seat).
- The system is suitable for liquid and gaseous media.
- The system is also suitable for vacuum applications.

Cavity pressure relieving over spring loaded seat

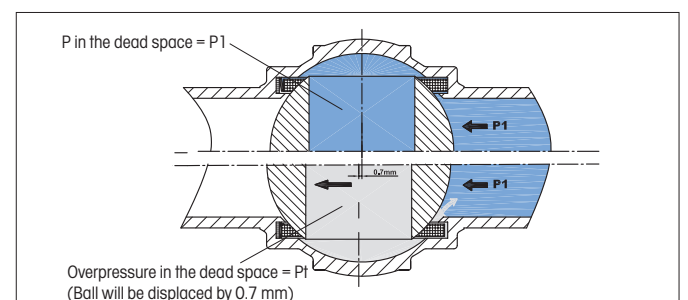
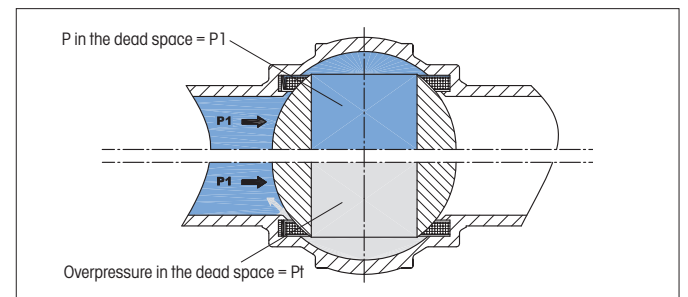

Subject to alterations

Product coding

P 0 5 0 5 T 4404 40 050

Connections

- D** – External threads
- E** – Internal threads
- G** – ANSI Class 150 lbs flanges in body material
- H** – ANSI Class 300 lbs flanges in body material
- L** – Short pattern DIN flanges in body material
- P** – DIN flanges in body material (DN10–65)*
- S** – Butt welding ends

Seat/packing material

- 0** – TFM Virgin/PTFE & graphite*

Certificates

- 5** – EN 10204 – 3.1*

Options

- 0** – No options*
- 3** – Pressure balancing hole (only DN 10,15)
- 5** – Grooved to EN 1092-1, Form D
- E** – Pressure balancing hole additional to the cavity pressure relief system

* Standard

Size

- 010** – DN 10
- 015** – DN 15 / 1/2"
- 020** – DN 20 / 3/4"
- 025** – DN 25 / 1"
- 032** – DN 32 / 1 1/4"
- 040** – DN 40 / 1 1/2"
- 050** – DN 50 / 2"
- 065** – DN 65 / 2 1/2"
- 080** – DN 80 / 3"
- 100** – DN 100 / 4"
- 150** – DN 150 / 6"

Pressure rating

- 16** – 16 bar (*DN 65–150)
- 25** – 25 bar
- 40** – 40 bar (*DN 10–50)
- 15** – 150 lbs (DN 15–150)
- 30** – 300 lbs (DN 15–150)

Body material

- 4404** – 1.4404*
- 4435** – 1.4435
- C276** – Hastelloy C 276

T – Cryogenic execution

Cavity pressure relief system

- 0** – Without* (only DN 10,15)
- 5** – Integrated*

Version_12.19



Other Products from Peter Meyer & Co. AG

Standard- and Tank Bottom Valves

- One-piece body design
- Full bore
- Laser welded, without body seal
- Chambered seats
- Integrated cavity pressure relief system

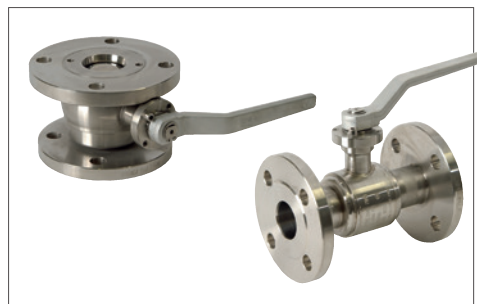

Segment Ball Valves

- Eccentric mounted shaft
- 2 piece design
- Full bore
- Seats in Metal, PEEK or TFM
- Suitable for resinous media such as adhesives and colorants, products with catalyst, and so on



Metal Seated Ball Valves

- One-piece or split body design
- Seats and ball surface coated
- Suitable for high temperature range, for abrasive, erosive and other wide range of applications



Ball Valves for Solids

- Trunnion mounted design
- Only one seat with pre-loaded spring element
- Full ball or segment
- Seat in metal, PEEK or TFM
- Suitable for dry and abrasive solids, such as powders, ash, and so on



Top Entry Segment Ball Valves

- Top Entry Design (Valve can be opened from the top)
- Access to the interior parts without removing the valve from the pipeline
- Eccentric mounted shaft
- No cavity
- Especially suitable for chemical, pharmaceutical and food industry in multipurpose plants where fast and good cleaning is required

