



ISO 9001 by L.R.
PED DIR. 2014/68/UE by L.R.
ATEX DIR. 2014/34/UE by B.V.
FIRE SAFE EXECUTION BS6755/API 607 by L.R.
FIRE SAFE TESTED ISO 10497 by L.R.
ISO 15848 by TÜV
ANTISTATIC DEVICE by L.R.
EAC CERTIFICATION by B.V.

TYPE
FX2
PN 10 ÷ 40
ANSI 150

NORME E DIRETTIVE APPLICATE DISPONIBILI AL SEGUENTE LINK:
STANDARD AND DIRECTIVE APPLIED AVAILABLE AT FOLLOWING LINK:
http://www.adlerspa.com/pdf/NORME_ADLER.pdf

**VALVOLE A SFERA "CORPO PIATTO"
SPLIT BODY PASSAGGIO TOTALE CON CAMICIA DI
RISCALDAMENTO**



ACTUATED
BALL VALVES
CERTIFIED
SIL 3 Capable
According to IEC 61508

FULL BORE ACCORDING
TO ISO 14313

CONSTRUCTION ACCORDING TO:
BS EN 12516-2 - ANSI B16.34
ISO 14313

BALL VALVES
"WAFER TYPE" FULL BORE SPLIT BODY WITH HEATING JACKET
ROBINETS A BOISSEAU SPHERIQUE
"WAFER" PASSAGE INTEGRAL 2 PIECES AVEC ENVELOPPE
FLANSCHKUGELHÄHNE IN "KOMPAKTBAUWEISE"
VOLLER DURCHGANG ZWEITEILIGES GEHÄUSE MIT HEIZMANTEL

WEB SITE: WWW.ADLERSPA.COM



ISO 9001 by L.R.
 PED DIR. 2014/68/UE by L.R.
 ATEX DIR. 2014/34/UE by B.V.
 FIRE SAFE EXECUTION BS6755/API 607 by L.R.
 FIRE SAFE TESTED ISO 10497 by L.R.
 ISO 15848 by TÜV
 ANTISTATIC DEVICE by L.R.
 EAC CERTIFICATION by B.V.

TYPE
FX2
 PN 10 ÷ 40
 ANSI 150

VALVOLA A SFERA "CORPO PIATTO" SPLIT BODY PASSAGGIO TOTALE CON CAMICIA DI RISCALDAMENTO
 BALL VALVES "WAFER TYPE" SPLIT BODY FULL BORE WITH HEATING JACKET
 ROBINETS A BOISSEAU SPHERIQUE "WAFER" PASSAGE INTEGRALE 2 PIECES AVEC ENVELOPPE
 FLANSCHKUGELHÄHNE IN "KOMPAKTBAUWEISE" VOLLER DURCHGANG ZWEITEILIGES GEHÄUSE MIT HEIZMANTEL

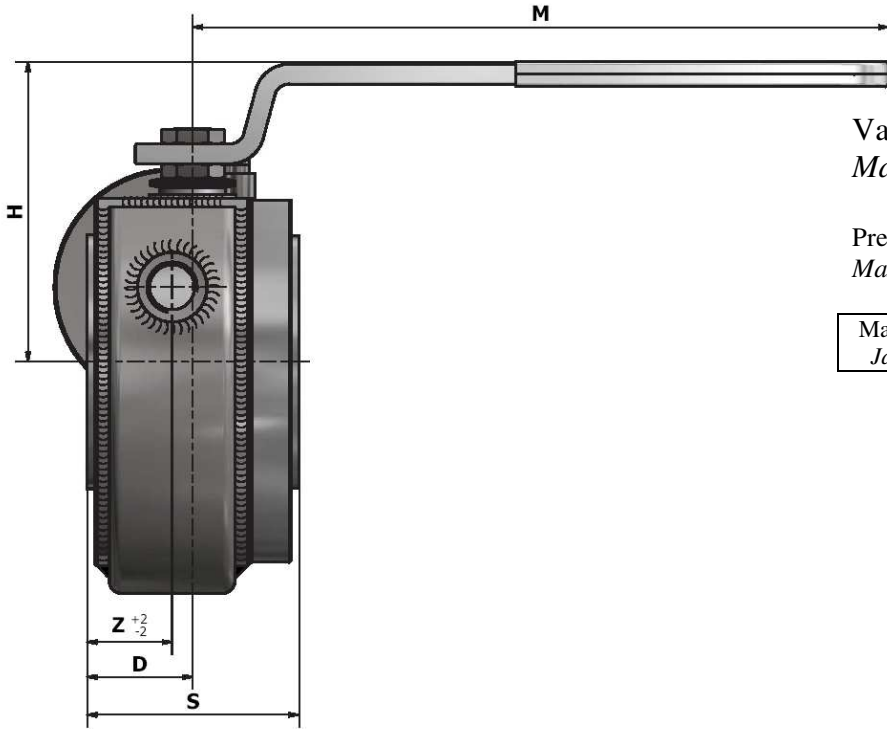

Valvola base FA2
 Main Ball Valve FA2

Pressione massima di lavoro nelle camicie 10 bar
 Maximum working pressure for jacket 10 bar

Materiale camicia Jacket material	CARBON STEEL (STANDARD) STAINLESS STEEL (OPTIONAL)
--------------------------------------	---

**VISUALIZZA 3D
 VIEW 3D**

<https://adlerspa.com/prodotti/fx2>

**FLANGE DIMENSIONS
 according to
 EN 1092-1 or ANSI B16.5**
 see table
<https://adlerspa.com/wp-content/uploads/2023/11/Tabella-dimensioni-flange-valvole-Adler.pdf>

DN 65 PN 16 ESECUZIONE STANDARD CON 4 FORI SU RICHIESTA DISPONIBILE CON 8 FORI
 DN 65 PN 16 STANDARD EXECUTION WITH 4 HOLES ON REQUEST AVAILABLE WITH 8 HOLES

DN 200
 -CONSIGLIATO RIDUTTORE MANUALE
 -MANUAL GEAR BOX SUGGESTED
 -REDUCTEUR MANUEL CONSEILLE
 -EMPFEHLEN WIR EIN HANDGETRIEBE

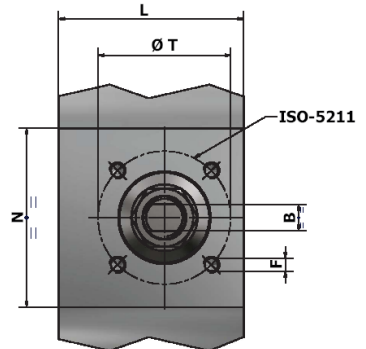
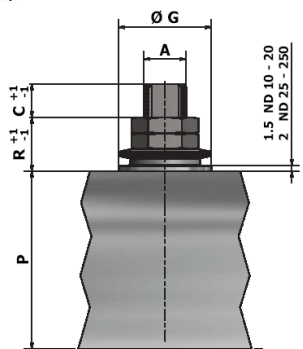
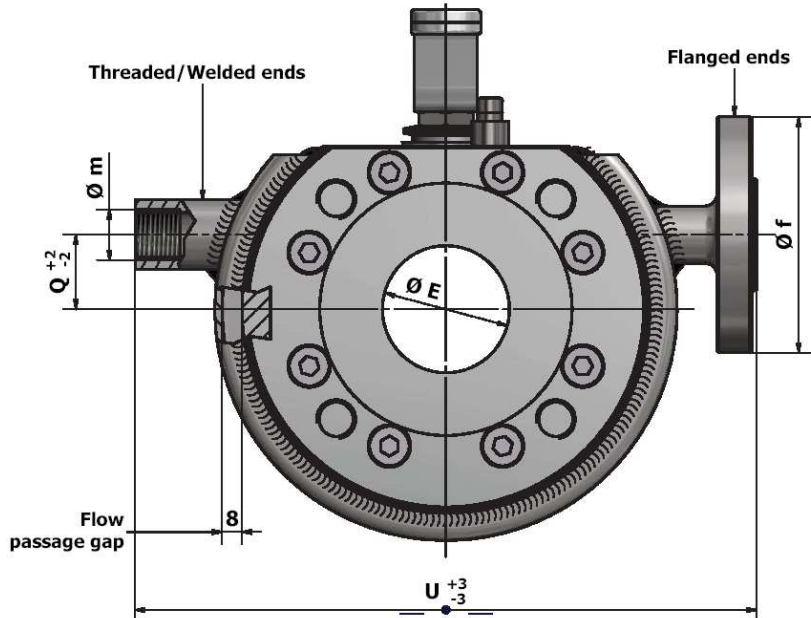



ISO 9001 by L.R.
 PED DIR. 2014/68/UE by L.R.
 ATEX DIR. 2014/34/UE by B.V.
 FIRE SAFE EXECUTION BS6755/API 607 by L.R.
 FIRE SAFE TESTED ISO 10497 by L.R.
 ISO 15848 by TÜV
 ANTISTATIC DEVICE by L.R.
 EAC CERTIFICATION by B.V.

TYPE
FX2
 PN 10 ÷ 40
 ANSI 150

N.	DESCRIZIONE DESCRIPTION DESCRIPTION BESCHREIBUNG	MATERIALI MATERIALS MATERIAUX WERKSTOFFE
1	CORPO BODY CORPS MITTE	ASTM A105 ASTM A479 304/304L ASTM A479 316/316L
2	LATERALE END LATERAL ENDE	ASTM A105 ASTM A479 304/304L ASTM A479 316/316L
3*	O-RING	FKM - (VITON)
4*	ANELLO SEAL ANNEAU DICHTUNGSRING	P.T.F.E.
5*	SEDE SEAT SIEGE SITZRING	P.T.F.E. + 15% FIBERGLASS
6	SFERA BALL BOULE KUGEL	ASTM A479 304/304L ASTM A351 CF8 ASTM A479 316/316L ASTM A351 CF8M
7	DISPOSITIVO ANTISTATICO ANTISTATIC DEVICE CONTACT ANTISTATIQUE ANTISTATIK VORRICHTUNG	ASTM A479 316/316L
8	STELO STEM TIGE SPINDEL	ASTM A479 304/304L ASTM A479 316/316L

N.	DESCRIZIONE DESCRIPTION DESCRIPTION BESCHREIBUNG	MATERIALI MATERIALS MATERIAUX WERKSTOFFE
9*	BUSSOLA STEM SEAL JOINT TIGE UNTERE SPINDELABDICHTUNG	P.T.F.E.
10*	PACCO A "V" CHEVRON RINGS JOINT A "V" 3 FACHE DACHMANSCHETTE	P.T.F.E. / GRAFITE P.T.F.E. / GRAPHITE P.T.F.E. / GRAPHITE P.T.F.E. / GRAPHIT
11	PREMIBUSSOLA PRESSING BUSH PRESSE RONDELLE STOPFBUCHSDRUCKRING	ASTM A479 304
12	MOLLE A TAZZA SPRING WASHERS RONDELLES BELLEVILLE TELLERFEDERN	C72/50Cr V4 ZINCATO - GALVANIZED - ZINGUE - VERZINKT X10CrNi18.8 ON REQUEST
13	VITE DI FERMO E FERMO PIN AND STOP PIN PLOT ET PLOT D'ARRET ANSCHLAGBOLZEN	UNI3740 8.8 ZINCATO - GALVANIZED - ZINGUE - VERZINKT UNI 3951 ON REQUEST A2-70
14	DADO - CONTRODADO NUT - LOCK NUT ECROU - CONTRE-ECROU MUTTER - KONTERMUTTER	UNI 3740 - ZINCATO - GALVANIZED 6S ZINGUE - VERZINKT ASTM A479 ON REQUEST 304
15	LEVA WRENCH LEVIER HANDHEBEL	AISI 1010 CHROMED FOR S.S. VALVES PAINTED FOR C.S. VALVES ASTM A479 ON REQUEST 304
16	VITE SCREW VIS SCHRAUBE	UNI 3740 8.8 ZINCATO - GALVANIZED - ZINGUE - VERZINKT UNI 3951 ON REQUEST A2-70

* RICAMBI CONSIGLIATI - RECOMMENDED SPARE PARTS - PIECES DE RECHANGE CONSEILLEES - ERSATZTEIL EMPFEHLUNG

ON REQUEST P.T.F.E. AVAILABLE CERTIFIED BAM, FDA, MOCA

DIMENSIONI - DIMENSION - DIMENSIONS - ABMESSUNGEN

DN	15	20	25	32	40	50	65	80	100	125	150	200	250
A	10	10	12	12	16	16	22	22	30	30	42	48	
B	6	6	8	8	10	10	14	14	18	18	28	32	
C	7	7	10	10	10	10	12	12	17	17	19	20	
D	17,5	17,5	21,5	25,5	32	S/2	S/2	S/2	S/2	S/2	S/2	S/2	
E	15	19	25	30	38	51	64	76	101	118	152	203	
F	M5	M5	M5	M5	M6	M6	M8	M8	M8	M10	M12	M16	
f	DN 15 PN 16						DN 25 PN 16						
ISO	F03	F03	F03	F03	F05	F05	F07	F07	F07	F10	F12	F14	
G	25	25	25	25	35	35	55	55	55	70	85	100	
H	66	68	85	91	110	120	144	152	174	188	256	294	
L	33	33	36.5	41	52	62	79	88	105	133	152	228	
M	145	145	185	185	280	280	370	370	470	650	750	900	
m	Ø1/2" GAS						Ø1" GAS						
N	69	78	81	105	81	102	85	80	86	100	110	95	
P	32,5	35	41	46,5	63	65	82	90.5	99.5	114	144	183	
Q	/	/	/	25	30	30	45	50	70	80	95	130	
R	8	8	17	17	13	21	24	24	27	26	34	36	
S	53	53	57	65	79	84	103	120	153.5	182	234	310	
T	36	36	36	36	50	50	70	70	70	102	125	140	
U	170	180	190	215	230	250	270	300	340	360	420	500	
Z	17,5	17,5	21,5	25,5	32	34	43	47	56	70	117	155	
Kg	4,3	5	6	9	12	14,5	21	27,5	39	55	95	127	

DN 15÷40 - OPTIONAL

PN 10÷40 - ANSI 150

- DATI E CARATTERISTICHE SOGGETTI A VARIAZIONI SENZA PREAVVISO
- SPECIFICATIONS SUBJECT TO MODIFICATIONS WITHOUT PRIOR NOTICE
- TOUS DROITS DE MODIFICATION RESERVES
- KONSTRUKTIONSÄNDERUNGEN VORBEHALTEN



ADLER SpA - BALL VALVES
 20010 S. STEFANO TICINO (MI) ITALY V.le BORLETTI, 14 Tel. +39/02974842.11 FAX +39/0297271698
 E-mail: adler@adlerspa.com <http://www.adlerspa.com>



ISO 9001 by L.R.
 PED DIR. 2014/68/UE by L.R.
 ATEX DIR. 2014/34/UE by B.V.
 FIRE SAFE EXECUTION BS6755/API 607 by L.R.
 FIRE SAFE TESTED ISO 10497 by L.R.
 ISO 15848 by TÜV
 ANTISTATIC DEVICE by L.R.
 EAC CERTIFICATION by B.V.

TYPE
FX2
 PN 10 ÷ 40
 ANSI 150

• ESECUZIONI • EXECUTIONS • EXECUTIONS • AUSFÜHRUNGEN



EXECUTION 4 - 12

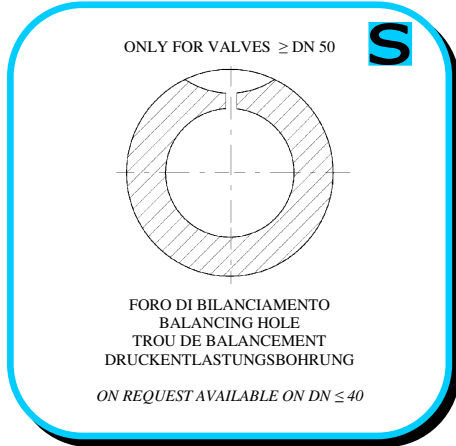

EXECUTION 6 - 16

S STANDARD

O OPTIONAL

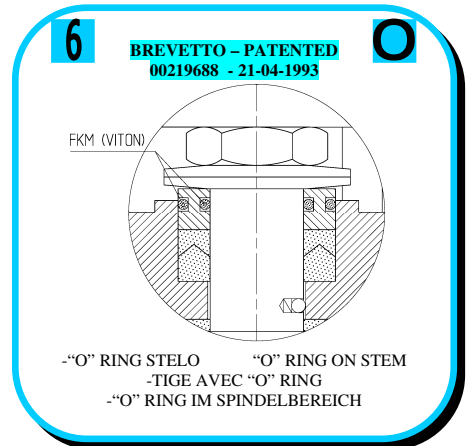
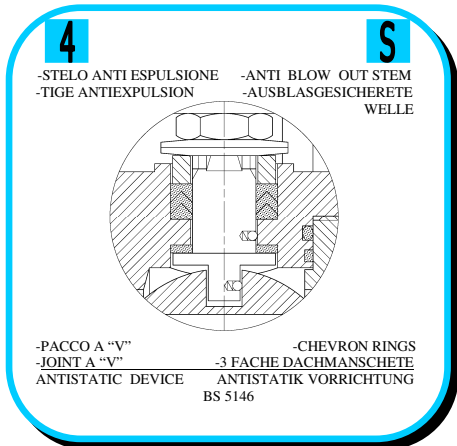
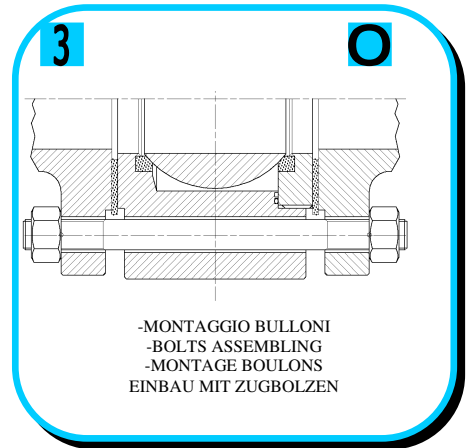
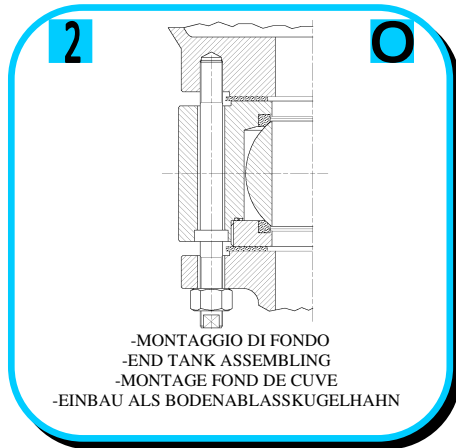
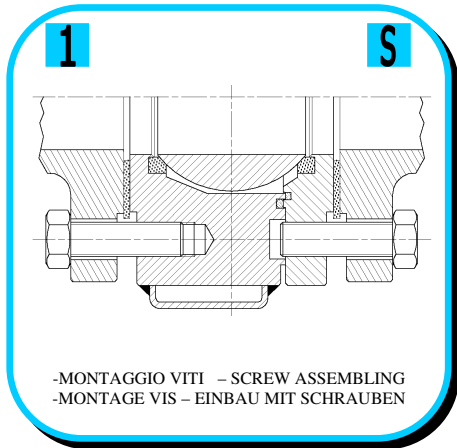





ISO 9001 by L.R.
 PED DIR. 2014/68/UE by L.R.
 ATEX DIR. 2014/34/UE by B.V.
 FIRE SAFE EXECUTION BS6755/API 607 by L.R.
 FIRE SAFE TESTED ISO 10497 by L.R.
 ISO 15848 by TÜV
 ANTISTATIC DEVICE by L.R.
 EAC CERTIFICATION by B.V.

TYPE
FX2
 PN 10 ÷ 40
 ANSI 150

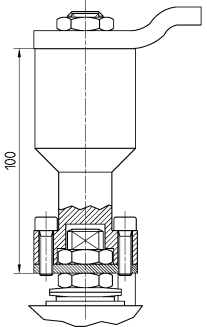
7 



-PROLUNGA STELO -STEM EXTENSION
 -TIGE PROLONGEE -SPINDELVERLÄNGERUNG

8 

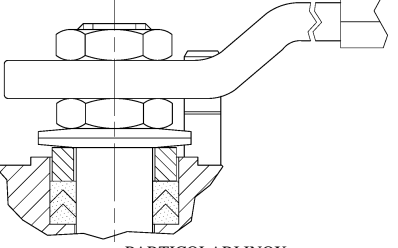

-PARTICOLARI INOX
 -STAINLESS STEEL DETAILS
 -ACCESSOIRES EN INOX
 -EDELSTAHLTEILE

9 

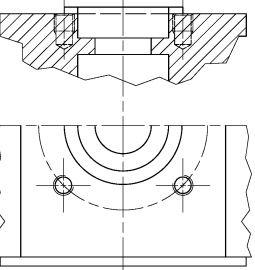

-ATTACCO "ISO" -"ISO" CONNECTIONS
 -SYSTEM "ISO" -ANSCHLUSS "ISO"

10 

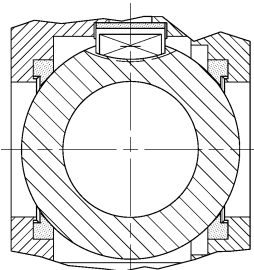

-SFERA CONTENUTA -CONTENTS BALL
 -BOULE CONTENUE
 -NICHT RAUSRAGENDE KUGEL

11 

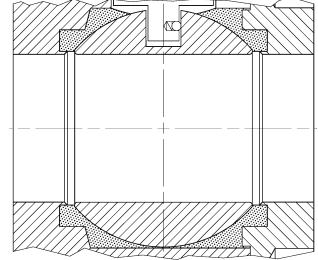

-TENUTE INTEGRALE -POCKETLESS SEATS
 -TENUUE INTEGRALE -TOTRAUMARM
 -P.T.F.E. / R.T.F.E.

12 

FIRE SAFE
 ISO 10497 "ISO-FT"
 (BS 6755 / API 607)



13 

BREVETTO - PATENTED
 00219619 - 21-04-1993

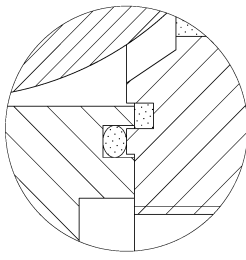

-DOPPIA TENUTA -DOUBLE SEALS
 -DOUBLE ETANCHEITE -DOPPELTE ABDICHTUNG
 -LATERALE A BATTUTA -METAL BEATING END
 -LATERAL AVEC BATTUE MECANIQUE
 -METALLISCHER ANSCHLAG DES
 GEGENGEHÄUSE

14 VEDERE / SEE ANSI B16.34 

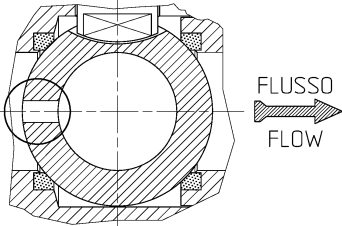

FLUSSO
 FLOW

-FORO DI SCARICO NELLA SFERA
 -OVERPRESSURE HOLE INTO BALL
 -TROU DECOMPRESSION DANS LA BOULE
 -ENTLASTUNGSBOHRUNG IN DER KUGEL
 VALVOLA MONO DIREZIONALE
 MONO-DIRECTIONAL VALVE

AQUILA - AEGLE - AIGLE
 ADLER



16 



-FIRE SAFE ISO FT+ "O" RING STELO
 -FIRE SAFE ISO FT+ "O" RING ON STEM
 -SECURITE FEU ISO FT+ TIGE AVEC "O" RING
 -FEUERSICHERE AUSFÜHRUNG ISO FT+
 "O" RING IM SPINDELBEREICH

17 

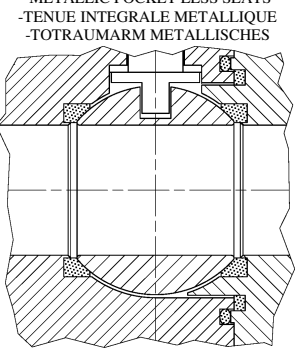

-TENUTA INTEGRALE METALLICA
 -METALLIC POCKETLESS SEATS
 -TENUUE INTEGRALE METALLIQUE
 -TOTRAUMARM METALLISCHES

18 

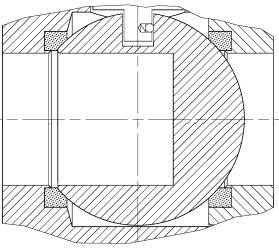

-SFERA CIECA PER CAMPIONATURA
 -BLIND BALL FOR SAMPLING
 -PRISE-ECHANTILLON
 KUGEL FÜR PROBEAHME

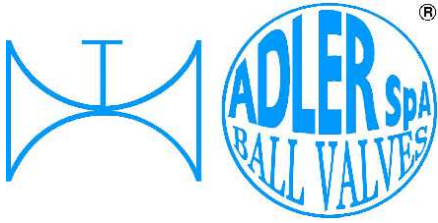

ISO 9001 by L.R.
 PED DIR. 2014/68/UE by L.R.
 ATEX DIR. 2014/34/UE by B.V.
 FIRE SAFE EXECUTION BS6755/API 607 by L.R.
 FIRE SAFE TESTED ISO 10497 by L.R.
 ISO 15848 by TÜV
 ANTISTATIC DEVICE by L.R.
 EAC CERTIFICATION by B.V.

TYPE
FX2
 PN 10 ÷ 40
 ANSI 150

VITI D'ASSEMBLAGGIO PER FX2 - ASSEMBLING SCREWS FOR FX2 - VIS D'ASSEMBLAGE POUR FX2- MONTAGESCHRAUBEN FÜR FX2

N° VITI - DIMENSIONE • N° SCREW - DIMENSIONS • N° VIS- DIMENSIONS • N° SCHRAUBEN-ABMESSUNGEN

EUROPEAN NORM

DN PN	10-15		20		25		32		40		50		65		80		100		125		150		200		250	
10																							16	M20 X50		
16	8	M12 X30	8	M12 X30	8	M12 X30	8	M16 X35	8	M16 X35	8	M16 X40	8	M16 X40	16	M16 X40	16	M16 X40	16	M16 X45	16	M20 X45	24	M20 X50	24	M24 X50
25	8	M12 X30	8	M12 X35	8	M12 X35	8	M16 X40	8	M16 X40	8	M16 X40	16	M16 X45	16	M16 X45	16	M20 X50	16	M24 X55	16	M24 X55	24	M24 X60	24	M27 X60
40	8	M12 X30	8	M12 X35	8	M12 X35	8	M16 X40	8	M16 X40	8	M16 X40	16	M16 X45	16	M16 X45	16	M20 X50	16	M24 X55	16	M24 X55	24	M27 X65	24	M30 X65

* N° 8 per UNI 2223/2229

ANSI METRIC

(STANDARD ADLER)

Ø Rating	1/2"		3/4"		1"		1 1/4"		1 1/2"		2"		2 1/2"		3"		4"		5"		6"		8"		10"	
150	8	M14 X30	8	M14 X30	8	M14 X30	8	M14 X35	8	M14 X35	8	M16 X40	8	M16 X40	8	M16 X45	16	M16 X45	16	M20 X50	16	M20 X50	16	M20 X50	24	M24 X70

ANSI B1.1 UNC

(ON REQUEST)

Ø Rating	1/2"		3/4"		1"		1 1/4"		1 1/2"		2"		2 1/2"		3"		4"		5"		6"		8"		10"	
150	8	1/2 X 1 1/4	8	1/2 X 1 1/4	8	1/2 X 1 1/4	8	1/2 X 1 1/4	8	5/8 X 1 1/4	8	5/8 X 1 1/2	8	5/8 X 1 3/4	8	5/8 X 1 3/4	16	5/8 X 1 3/4	16	3/4 X 2	16	3/4 X 2	16	3/4 X 2	24	7/8 X 2 3/4

Length of screws calculated considering a gasket with thickness of 2mm.

