



ISO 9001 by L.R.
PED DIR. 2014/68/UE by L.R.
ATEX DIR. 2014/34/UE by B.V.
FIRE SAFE EXECUTION BS6755/API 607 by L.R.
FIRE SAFE TESTED ISO 10497 by L.R.
ISO 15848 by TÜV
ANTISTATIC DEVICE by L.R.
EAC CERTIFICATION by B.V.

TYPE
FB2
PN 10 ÷ 40
ANSI 150 ÷ 300

NORME E DIRETTIVE APPLICATE DISPONIBILI AL SEGUENTE LINK:
STANDARD AND DIRECTIVE APPLIED AVAILABLE AT FOLLOWING LINK:
http://www.adlerspa.com/pdf/NORME_ADLER.pdf

VALVOLE A SFERA "CORPO PIATTO" SPLIT BODY PASSAGGIO TOTALE

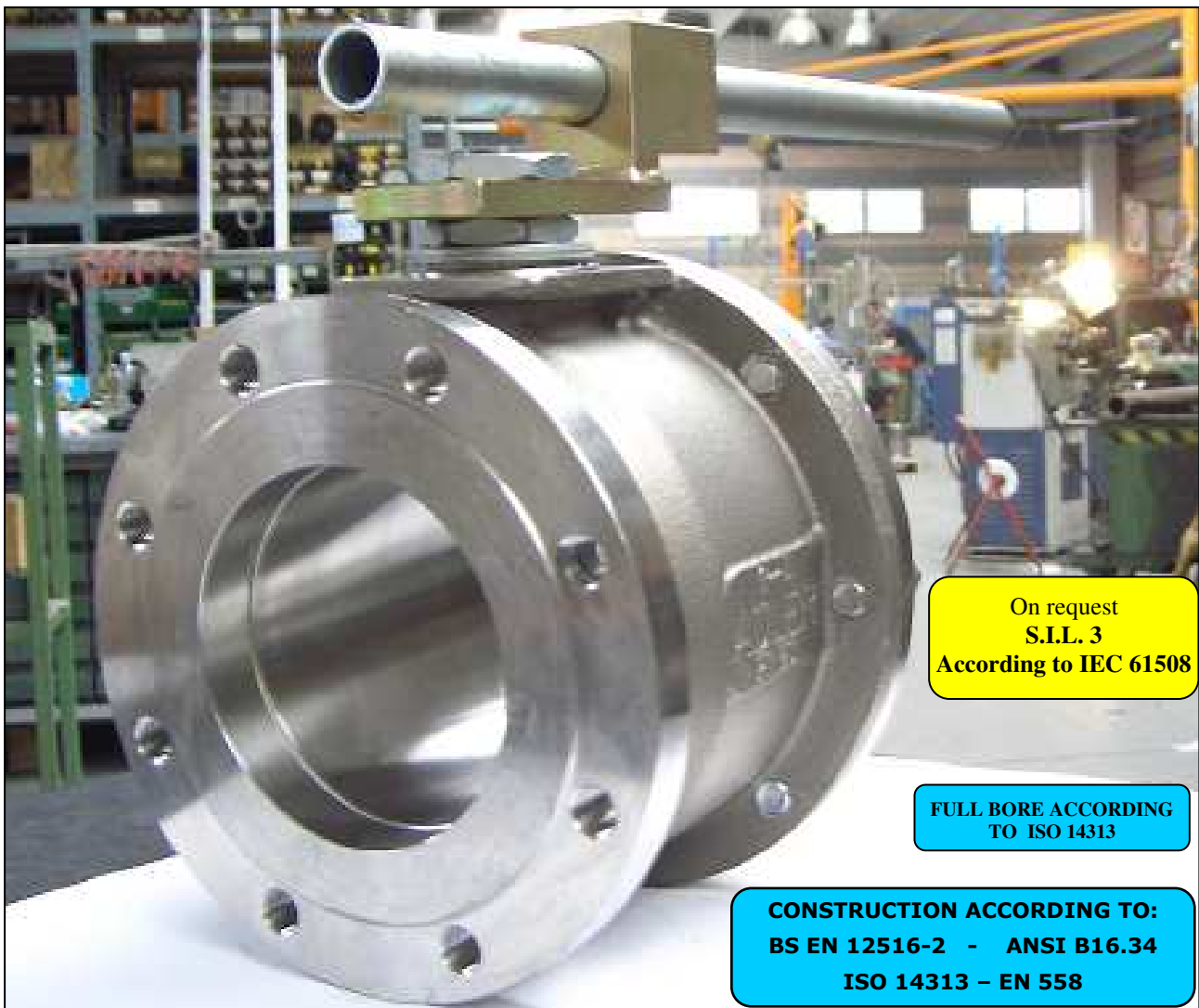

On request
S.I.L. 3
According to IEC 61508

FULL BORE ACCORDING
TO ISO 14313

CONSTRUCTION ACCORDING TO:
BS EN 12516-2 - ANSI B16.34
ISO 14313 - EN 558

BALL VALVES
"WAFFER TYPE" FULL BORE SPLIT BODY
ROBINETS A BOISSEAU SPHERIQUE
"WAFFER" PASSAGE INTEGRAL 2 PIECES
FLANSCHKUGELHÄHNE IN "KOMPAKTBAUWEISE"
VOLLER DURCHGANG ZWEIFTEILIGES GEHÄUSE

WEB SITE: WWW.ADLERSPA.COM



ISO 9001 by L.R.
 PED DIR. 2014/68/UE by L.R.
 ATEX DIR. 2014/34/UE by B.V.
 FIRE SAFE EXECUTION BS6755/API 607 by L.R.
 FIRE SAFE TESTED ISO 10497 by L.R.
 ISO 15848 by TÜV
 ANTISTATIC DEVICE by L.R.
 EAC CERTIFICATION by B.V.

TYPE
FB2
 PN 10 ÷ 40
 ANSI 150 ÷ 300

VALVOLA A SFERA "CORPO PIATTO" SPLIT BODY PASSAGGIO TOTALE
 BALL VALVES "WAFER TYPE" SPLIT BODY FULL BORE
 ROBINETS A BOISSEAU SPHERIQUE "WAFER" PASSAGE INTEGRAL 2 PIECES
 FLANSCHKUGELHÄHNE IN "KOMPAKTBAUWEISE" VOLLER DURCHGANG ZWEITEILIGES GEHÄUSE

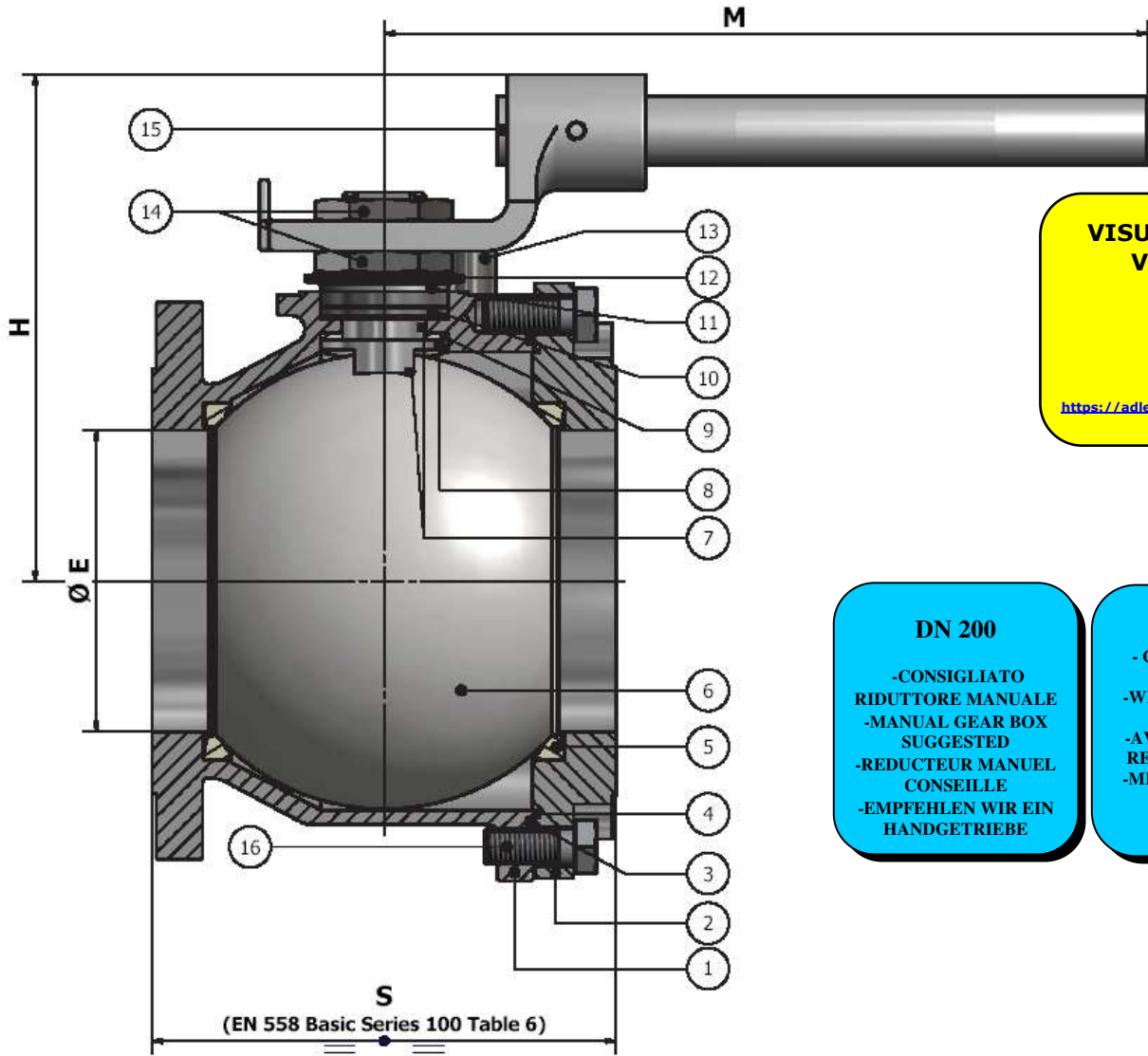

**VISUALIZZA 3D
 VIEW 3D**

<https://adlerspa.com/prodotti/fb2>

DN 200

- CONSIGLIATO RIDUTTORE MANUALE
- MANUAL GEAR BOX SUGGESTED
- REDUCTEUR MANUEL CONSEILLE
- EMPFEHLEN WIR EIN HANDGETRIEBE

DN 250

- CON ATTUATORE O RIDUTTORE
- WITH ACTUATORS OR GEAR BOX
- AVEC ACTIONEUR AU REDUCTEUR MANUEL
- MIT PNEUMATISCHER AUSLÖSER ODER HANDGETRIEBE

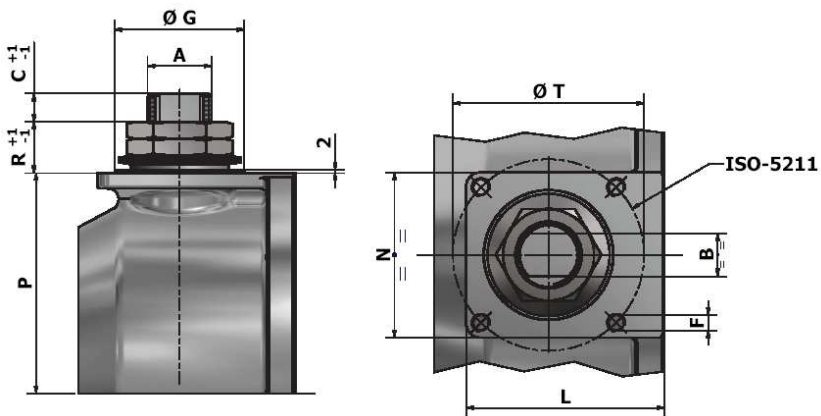



ISO 9001 by L.R.
 PED DIR. 2014/68/UE by L.R.
 ATEX DIR. 2014/34/UE by B.V.
 FIRE SAFE EXECUTION BS6755/API 607 by L.R.
 FIRE SAFE TESTED ISO 10497 by L.R.
 ISO 15848 by TÜV
 ANTISTATIC DEVICE by L.R.
 EAC CERTIFICATION by B.V.

TYPE
FB2
 PN 10 ÷ 40
 ANSI 150 ÷ 300

N.	DESCRIZIONE DESCRIPTION BESCHREIBUNG	MATERIALI MATERIALS MATERIAUX WERKSTOFFE
1	CORPO BODY CORPS MITTE	ASTM A 351 CF8M ASTM A 351 CF8
2	LATERALE INSERT LATERAL ENDE	ASTM A479 316/316L ASTM A 351 CF8M ASTM A479 304/304L ASTM A 351 CF8
3*	O-RING	FKM - (VITON)
4*	ANELLO SEAL ANNEAU DICHTUNGSRING	P.T.F.E.
5*	SEDE SEAT SIEGE SITZRING	P.T.F.E. R.P.T.F.E. (OPTIONAL)
6	SFERA BALL BOULE KUGEL	ASTM A479 304/304L ASTM A351 CF8 ASTM A479 316/316L ASTM A351 CF8M
7	DISPOSITIVO ANTISTATICO ANTISTATIC DEVICE CONTACT ANTISTATIQUE ANTISTATIK VORRICHTUNG	ASTM A479 316/316L
8	STELO STEM TIGE SPINDEL	ASTM A479 304/304L ASTM A479 316/316L

N.	DESCRIZIONE DESCRIPTION BESCHREIBUNG	MATERIALI MATERIALS MATERIAUX WERKSTOFFE
9*	BUSSOLA STEM SEAL JOINT TIGE UNTERE SPINDELABDICHTUNG	P.T.F.E.
10*	PACCO A "V" CHEVRON RINGS JOINT A "V" 3 FACHE DACHMANSCHETTE	P.T.F.E. / GRAFITE P.T.F.E. / GRAPHITE P.T.F.E. / GRAPHITE P.T.F.E. / GRAPHIT
11	PREMIBUSSOLA PRESSING BUSH PRESSE RONDELLE STOPFBUCHSDRUCKRING	ASTM A479 304
12	MOLLE A TAZZA SPRING WASHERS RONDELLES BELLEVILLE TELLERFEDERN	C72/50Cr V4 ZINCATO - GALVANIZED - ZINGUE - VERZINKT X10CrNi18.8 ON REQUEST
13	VITE DI FERMO E FERMO PIN AND STOP PIN PLOINT ET PLOT D'ARRET ANSCHLAGBOLZEN	UNI3740 8.8 ZINCATO - GALVANIZED - ZINGUE - VERZINKT UNI 3951 A2-70 ON REQUEST
14	DADO - CONTRODADO NUT - LOCK NUT ECROU - CONTRE-ECROU MUTTER - KONTERMUTTER	UNI 3740 - 65 ZINCATO - GALVANIZED - ZINGUE - VERZINKT ASTM A479 304 ON REQUEST
15	LEVA WRENCH LEVIER HANDHEBEL	AISI 1010 CHROMED FOR S.S. VALVES PAINTED FOR C.S. VALVES ASTM A479 304 ON REQUEST
16	VITE SCREW VIST SCHRAUBE	UNI 3740 8.8 ZINCATO - GALVANIZED - ZINGUE - VERZINKT UNI 3951 A2-70 ON REQUEST

* RICAMBI CONSIGLIATI - RECOMMENDED SPARE PARTS - PIECES DE RECHANGE CONSEILLEES - ERSATZTEIL EMPFEHLUNG

ON REQUEST P.T.F.E. AVAILABLE CERTIFIED BAM, FDA, MOCA

DIMENSIONI - DIMENSION - DIMENSIONS - ABMESSUNGEN

DN	10	15	20	25	32	40	50	65	80	100	125	150	200	250	300
A												42	48	56	
B												28	32	36	
C												19	20	20	
E												152	203	254	
F												M12	M16	M20	
ISO												F12	F14	F16	
G												85	100	130	
H												256	294	/	
L												116	135	153	
M												750	900	/	
N												113	135	153	
P												144	183	220	
R												34	36	45	
P												144	/	/	
R												34	/	/	
S												/	335	/	
S												234	310	389	
T												125	140	165	
~Kg												57	92	160	

- DATI E CARATTERISTICHE SOGGETTI A VARIAZIONI SENZA PREAVVISO
- SPECIFICATIONS SUBJECT TO MODIFICATIONS WITHOUT PRIOR NOTICE
- TOUS DROITS DE MODIFICATION RESERVES
- KONSTRUKTIONSÄNDERUNGEN VORBEHALTEN

PN 10 ÷ 40 ANSI 150

ANSI 300



ADLER SpA - BALL VALVES
 20010 S. STEFANO TICINO (MI) ITALY V.le BORLETTI, 14 Tel. +39/02974842.11 FAX +39/0297271698
 E-mail: adler@adlerspa.com <http://www.adlerspa.com>



ISO 9001 by L.R.
 PED DIR. 2014/68/UE by L.R.
 ATEX DIR. 2014/34/UE by B.V.
 FIRE SAFE EXECUTION BS6755/API 607 by L.R.
 FIRE SAFE TESTED ISO 10497 by L.R.
 ISO 15848 by TÜV
 ANTISTATIC DEVICE by L.R.
 EAC CERTIFICATION by B.V.

TYPE
FB2
 PN 10 ÷ 40
 ANSI 150 ÷ 300

· ESECUZIONI · EXECUTIONS · EXECUTIONS · AUSFÜHRUNGEN



EXECUTION 4 - 12

ONLY FOR VALVES \geq DN 50 **S**

FORO DI BILANCIAMENTO
 BALANCING HOLE
 TROU DE BALANCEMENT
 DRUCKENTLASTUNGSBOHRUNG

ON REQUEST AVAILABLE ON $DN \leq 40$



EXECUTION 6 - 16

S STANDARD

O OPTIONAL

1 **S**

-MONTAGGIO VITI - SCREW ASSEMBLING
 -MONTAGE VIS - EINBAU MIT SCHRAUBEN

2 **O**

-MONTAGGIO DI FONDO
 -END TANK ASSEMBLING
 -MONTAGE FOND DE CUVE
 -EINBAU ALS BODENABLASSKUGELHAHN

VALVOLE CERTIFICATE S.I.L. 3
 VALVES CERTIFIED S.I.L. 3

4 **S**

-STELO ANTI ESPULSIONE -ANTI BLOW OUT STEM
 -TIGE ANTIEXPULSION -AUSBLASGESICHERETE WELLE

-PACCO A "V" -CHEVRON RINGS
 -JOINT A "V" -3 FACHE DACHMANSCHETE
 ANTISTATIC DEVICE ANTISTATIK VORRICHTUNG
 BS 5146

PED CERTIFICATION

6 **O**

BREVETTO - PATENTED
 00219688 - 21-04-1993
 FKM (VITON)

-“O” RING STELO “O” RING ON STEM
 -TIGE AVEC “O” RING
 -“O” RING IM SPINDELBEREICH

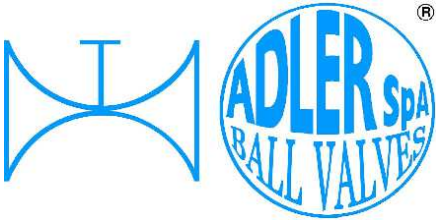

ISO 9001 by L.R.
 PED DIR. 2014/68/UE by L.R.
 ATEX DIR. 2014/34/UE by B.V.
 FIRE SAFE EXECUTION BS6755/API 607 by L.R.
 FIRE SAFE TESTED ISO 10497 by L.R.
 ISO 15848 by TÜV
 ANTISTATIC DEVICE by L.R.
 EAC CERTIFICATION by B.V.

TYPE
FB2
 PN 10 ÷ 40
 ANSI 150 ÷ 300

7

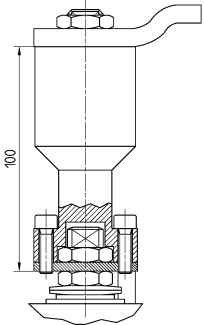

-PROLUNGA STELO -STEM EXTENSION
 -TIGE PROLONGEE -SPINDELVERLÄNGERUNG

8

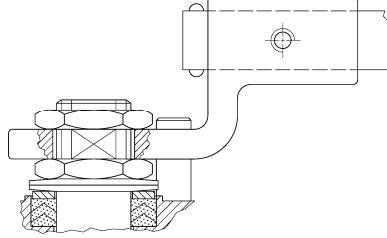

-PARTICOLARI INOX
 -STAINLESS STEEL DETAILS
 -ACCESSOIRES EN INOX
 -EDELSTAHLTEILE

9

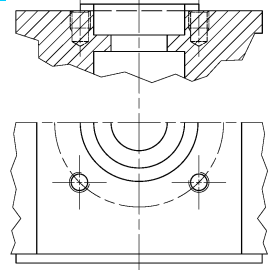

-ATTACCO "ISO" -"ISO" CONNECTIONS
 -SYSTEM "ISO" -ANSCHLUSS "ISO"

10

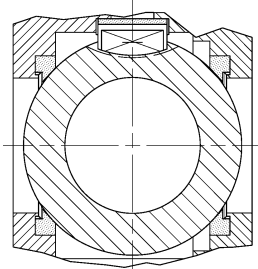

-SFERA CONTENUTA -CONTENTS BALL
 -BOULE CONTENUE
 -NICHT RAUSRAGENDE KUGEL

11

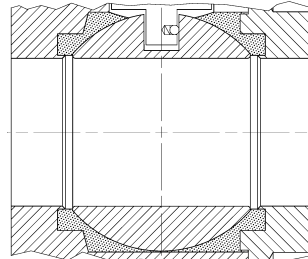

-TENUTE INTEGRALE -POCKETLESS SEATS
 -TENUE INTEGRALE -TOTRAUMARM
 -P.T.F.E. / R.T.F.E.

12

FIRE SAFE
 ISO 10497 "ISO-FT"
 (BS 6755 / API 607)



13

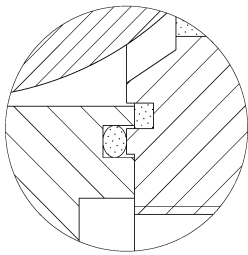

BREVETTO - PATENTED
 00219619
 -DOPPIA TENUTA -DOUBLE SEALS
 -DOUBLE ETANCHEITE -DOPPELTE ABDICHTUNG
 -GHIERA A BATTUTA -METAL BEATING RING
 -EMBOUT AVEC BATTUE MECANIQUE
 -METALLISCHER ANSCHLAG DES
 GEWINDEDRUCKRINGS

14

VEDERE / SEE ANSI B16.34

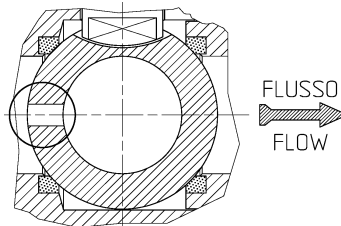

FLUSSO
 FLOW

-FORO DI SCARICO NELLA SFERA
 -OVERPRESSURE HOLE INTO BALL
 -TROU DECOMPRESSION DANS LA BOULE
 -ENTLASTUNGSBOHRUNG IN DER KUGEL
 VALVOLA MONO DIREZIONALE
 MONO-DIRECTIONAL VALVE

15

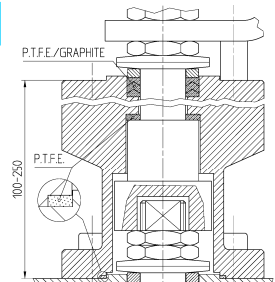

-SERVIZIO CRIOGENICO - CRYOGENIC SERVICE
 -SERVICE CRYOGENIQUE
 -TIEFTEMPORATUR SERVICE

16



-FIRE SAFE ISO FT+ "O" RING STELO
 -FIRE SAFE ISO FT+ "O" RING ON STEM
 -SECURITE FEU ISO FT+ TIGE AVEC "O" RING
 -FEUERSICHERE AUSFÜHRUNG ISO FT+
 "O" RING IM SPINDELBEREICH

17

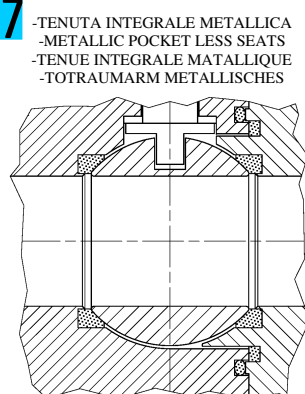

-TENUTA INTEGRALE METALLICA
 -METALLIC POCKET LESS SEATS
 -TENUE INTEGRALE METALLIQUE
 -TOTRAUMARM METALLISCHES

18

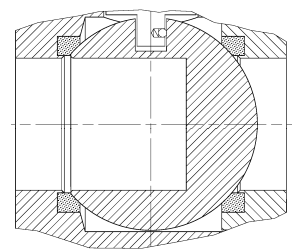

-SFERA CIECA PER CAMPIONATURA
 -BLIND BALL FOR SAMPLING
 -PRISE-ECHANTILLON
 KUGEL FÜR PROBENAHME

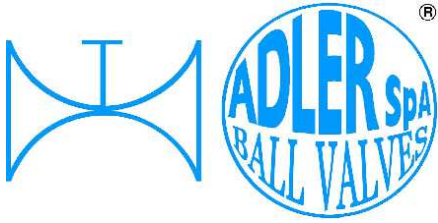

ISO 9001 by L.R.
 PED DIR. 2014/68/UE by L.R.
 ATEX DIR. 2014/34/UE by B.V.
 FIRE SAFE EXECUTION BS6755/API 607 by L.R.
 FIRE SAFE TESTED ISO 10497 by L.R.
 ISO 15848 by TÜV
 ANTISTATIC DEVICE by L.R.
 EAC CERTIFICATION by B.V.

TYPE
FB2
 PN 10 ÷ 40
 ANSI 150 ÷ 300

VITI D'ASSEMBLAGGIO PER FB2 - ASSEMBLING SCREWS FOR FB2 - VIS D'ASSEMBLAGE POUR FB2- MONTAGESCHRAUBEN FÜR FB2

N° VITI – DIMENSIONE • N° SCREW – DIMENSIONS • N° VIS- DIMENSIONS • N° SCHRAUBEN-ABMESSUNGEN

EUROPEAN NORM

DN PN	20	25	32	40	50	65	80	100	125	150	200	250			
10										16	M20 X45	16	M20 X50	24	M20 X60
16										16	M20 X45	24	M20 X50	24	M24 X65
25										16	M24 X55	24	M24 X60		
40										16	M24 X55	24	M27 X65		

* N° 8 per UNI 2223/2229

ANSI METRIC

(STANDARD ADLER)

Ø Rating	¾"	1"	1 ¼"	1 ½"	2"	2 ½"	3"	4"	5"	6"	8"	10"			
150										16	M20 X50	16	M20 X50		
300										24	M20 X60	24	M24 X60		

ANSI B1.1 UNC

(ON REQUEST)

Ø Rating	¾"	1"	1 ¼"	1 ½"	2"	2 ½"	3"	4"	5"	6"	8"	10"			
150										16	3/4 X 2	16	3/4 X 2		
300										24	3/4 X 2 ½	24	7/8 X 2 ¾		

Length of screws calculated considering a gasket with thickness of 2mm.

