

ISO 9001 by L.R.  
PED DIR. 2014/68/UE by L.R.  
ATEX DIR. 2014/34/UE by B.V.  
FIRE SAFE EXECUTION BS6755/API 607 by L.R.  
FIRE SAFE TESTED ISO 10497 by L.R.  
ISO 15848 by TÜV  
ANTISTATIC DEVICE by L.R.  
EAC CERTIFICATION by B.V.

TYPE  
**FM2**  
PN 10 ÷ 40

NORME E DIRETTIVE APPLICATE DISPONIBILI AL SEGUENTE LINK:  
STANDARD AND DIRECTIVE APPLIED AVAILABLE AT FOLLOWING LINK:  
[http://www.adlerspa.com/pdf/NORME\\_ADLER.pdf](http://www.adlerspa.com/pdf/NORME_ADLER.pdf)

## VALVOLE A SFERA "UNI EN 558-1" SPLIT BODY PASSAGGIO TOTALE



**BALL VALVES**  
**"UNI EN 558-1" FULL BORE SPLIT BODY**  
**ROBINETS A BOISSEAU SPHERIQUE**  
**"UNI EN 558-1" PASSAGE INTEGRAL 2 PIECES**  
**FLANSCHKUGELHÄHNE IN "UNI EN 558-1"**  
**VOLLER DURCHGANG ZWEITEILIGES GEHÄUSE**

WEB SITE: [WWW.ADLERSPA.COM](http://WWW.ADLERSPA.COM)

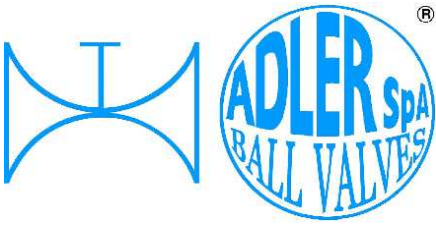

ISO 9001 by L.R.  
 PED DIR. 2014/68/UE by L.R.  
 ATEX DIR. 2014/34/UE by B.V.  
 FIRE SAFE EXECUTION BS6755/API 607 by L.R.  
 FIRE SAFE TESTED ISO 10497 by L.R.  
 ISO 15848 by TÜV  
 ANTISTATIC DEVICE by L.R.  
 EAC CERTIFICATION by B.V.

TYPE  
**FM2**  
 PN 10 ÷ 40

**VALVOLA A SFERA "UNI EN 558-1" SPLIT BODY PASSAGGIO TOTALE**  
**BALL VALVES "UNI EN 558-1" SPLIT BODY FULL BORE**  
**ROBINETS A BOISSEAU SPHERIQUE "UNI EN 558-1" PASSAGE INTEGRAL 2 PIECES**  
**FLANSCHKUGELHÄHNE IN "UNI EN 558-1" VOLLER DURCHGANG ZWEIFTEILIGES GEHÄUSE**

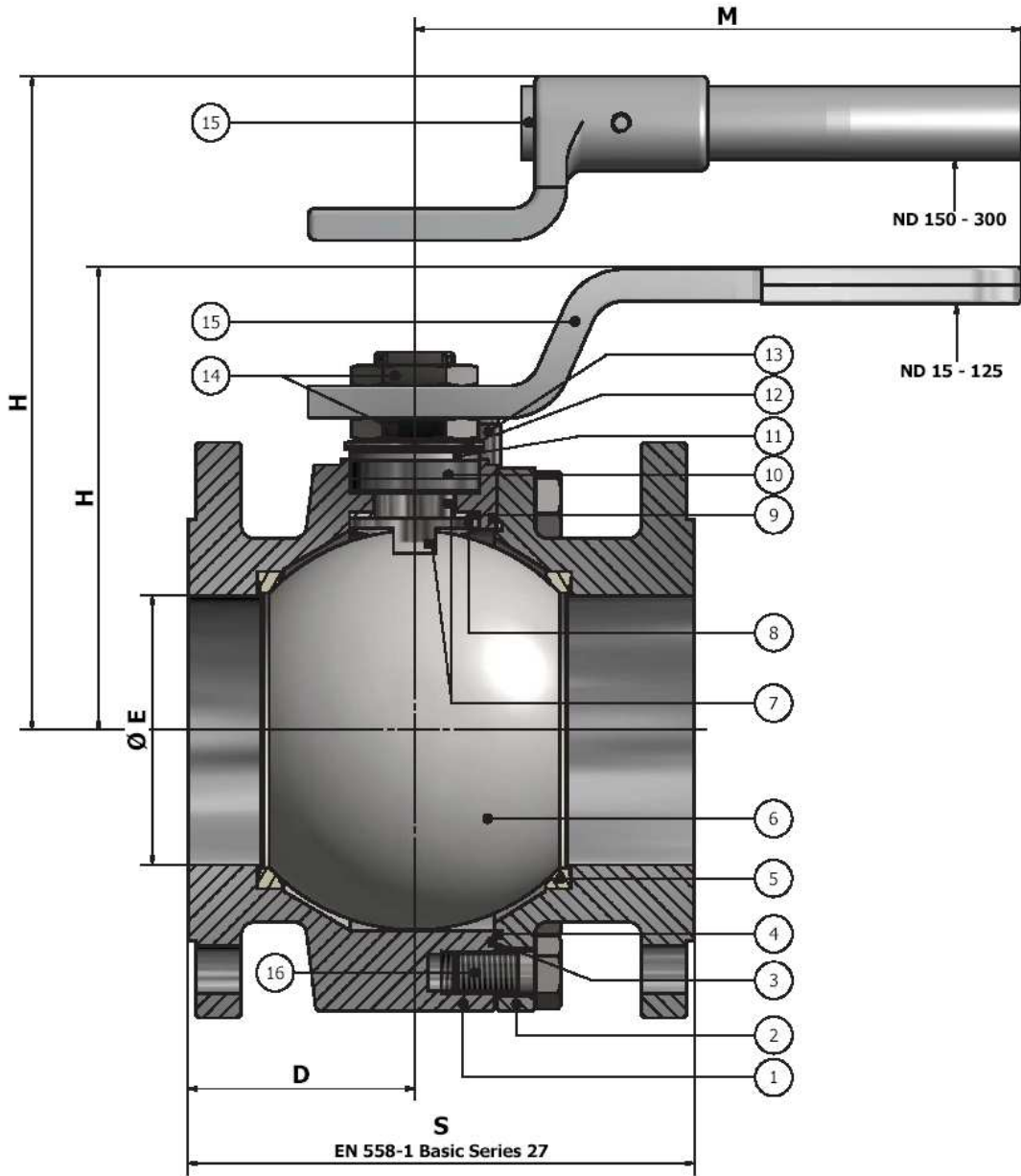

**DN 200 ÷ 300**  
 -CONSIGLIATO  
 RIDUTTORE MANUALE  
 -MANUAL GEAR BOX  
 SUGGESTED  
 -REDUCTEUR MANUEL  
 CONSEILLE  
 -EMPFEHLEN WIR EIN  
 HANDGETRIEBE

**VISUALIZZA 3D  
 VIEW 3D**

<https://adlerspa.com/prodotti/fg2>

DN 65 PN 16 ESECUZIONE  
 STANDARD CON 4 FORI  
 SU RICHIESTA DISPONIBILE  
 CON 8 FORI  
 DN 65 PN 16 STANDARD  
 EXECUTION WITH 4 HOLES  
 ON REQUEST AVAILABLE WITH  
 8 HOLES

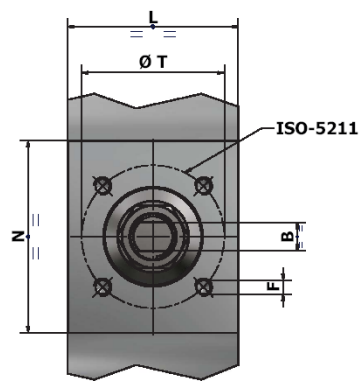
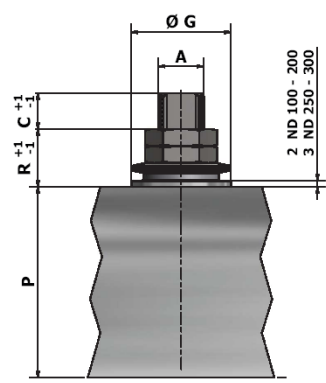

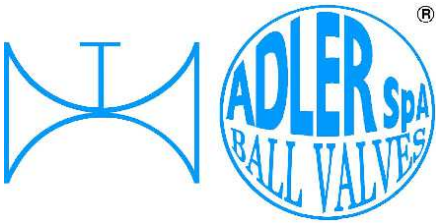

ISO 9001 by L.R.  
 PED DIR. 2014/68/UE by L.R.  
 ATEX DIR. 2014/34/UE by B.V.  
 FIRE SAFE EXECUTION BS6755/API 607 by L.R.  
 FIRE SAFE TESTED ISO 10497 by L.R.  
 ISO 15848 by TÜV  
 ANTISTATIC DEVICE by L.R.  
 EAC CERTIFICATION by B.V.

TYPE  
**FM2**  
 PN 10 ÷ 40

N.	DESCRIZIONE DESCRIPTION DESCRIPTION BESCHREIBUNG	MATERIALI MATERIALS MATERIAUX WERKSTOFFE
1	CORPO BODY CORPS MITTE	ASTM A105 ASTM A479 304/304L ASTM A479 316/316L ASTM A 351 CF8M
2	LATERALE END LATERAL ENDE	ASTM A105 ASTM A479 304/304L ASTM A479 316/316L ASTM A 351 CF8M
3*	O-RING	FKM - (VITON)
4*	ANELLO SEAL ANNEAU DICHTUNGSRING	P.T.F.E.
5*	SEDE SEAT SIEGE SITZRING	P.T.F.E. R.P.T.F.E. (OPTIONAL)
6	SFERA BALL BOULE KUGEL	ASTM A479 304/304L ASTM A351 CF8 ASTM A479 316/316L ASTM A351 CF8M
7	DISPOSITIVO ANTISTATICO ANTISTATIC DEVICE CONTACT ANTISTATIQUE ANTISTATIK VORRICHTUNG	ASTM A479 316/316L
8	STELO STEM TIGE SPINDEL	ASTM A479 304/304L ASTM A479 316/316L

N.	DESCRIZIONE DESCRIPTION DESCRIPTION BESCHREIBUNG	MATERIALI MATERIALS MATERIAUX WERKSTOFFE
9*	BUSSOLA STEM SEAL JOINT TIGE UNTERE SPINDELABDICHTUNG	P.T.F.E.
10*	PACCO A "V" CHEVRON RINGS JOINT A "V" 3 FACHE DACHMANSCHETTE	P.T.F.E. / GRAFITE P.T.F.E. / GRAPHITE P.T.F.E. / GRAPHIT
11	PREMIBUSSOLA PRESSING BUSH PRESSE RONDELLE STOPFBUCHSDRUCKRING	ASTM A479 304
12	MOLLE A TAZZA SPRING WASHERS RONDELLES BELLEVILLE TELLERFEDERN	C72/50Cr V4 ZINCATO - GALVANIZED - ZINGUE - VERZINKT X10CrNi18.8 ON REQUEST
13	VITE DI FERMO E FERMO PIN AND STOP PIN PLONT ET PLOT D'ARRET ANSCHLAGBOLZEN	UNI3740 8.8 ZINCATO - GALVANIZED - ZINGUE - VERZINKT UNI 3951 A2-70 ON REQUEST
14	DADO - CONTRODADO NUT - LOCK NUT ECROU - CONTRE-ECROU MUTTER - KONTERMUTTER	UNI 3740 - ZINCATO - GALVANIZED 6S ZINGUE - VERZINKT ASTM A479 ON REQUEST 304
15	LEVA WRENCH LEVIER HANDHEBEL	AISI 1010 CHROMED FOR S.S. VALVES PAINTED FOR C.S. VALVES ASTM A479 ON REQUEST 304
16	VITE SCREW VIS SCHRAUBE	UNI 3740 8.8 ZINCATO - GALVANIZED - ZINGUE - VERZINKT UNI 3951 ON REQUEST A2-70

\* RICAMBI CONSIGLIATI - RECOMMENDED SPARE PARTS - PIECES DE RECHANGE CONSEILLEES - ERSATZTEIL EMPFEHLUNG

ON REQUEST P.T.F.E. AVAILABLE CERTIFIED BAM, FDA, MOCA

## DIMENSIONI - DIMENSION - DIMENSIONS - ABMESSUNGEN

DN	15	20	25	32	40	50	65	80	100	125	150	200	250	300
A	10	10	12	12	16	16	22	22	30	30	42	48	56	56
B	6	6	8	8	10	10	14	14	18	18	28	32	36	36
C	7	7	10	10	10	10	12	12	16,5	16,5	19	20	20	20
D	49	51,5	50	51,5	59	61,5	70,5	73	85	100	144	180.5	196	237
D											117	155		
E	15	19	25	30	38	51	64	76	101	118	152	203	254	305
F	M5	M5	M5	M5	M6	M6	M8	M8	M8	M10	M12	M16	M20	M20
ISO	F03	F03	F03	F03	F05	F05	F07	F07	F07	F10	F12	F14	F16	F16
G	25	25	25	25	35	35	55	55	55	70	85	100	130	130
H	86	88	113	119	110	120	144	152	174	188	256	294	343	381
L	35	35	35	35	46,5	46,5	64,5	64,5	72	93	111	130	153	153
M	145	145	185	185	280	280	370	370	470	650	750	900	1000	1000
N	58	58	58	58	72,5	72,5	90	90	70	97	108	126	153	153
P	33,7	36	49,3	54,8	64,8	74,8	93,5	102	99,5	119	144	183	220	258,5
R	7	7	9	9	10	10	11	11	26	26	34	37	45	45
S	115	120	125	130	140	150	170	180	190	325	350	400	450	500
T	36	36	36	36	50	50	70	70	70	102	125	140	165	165
Kg	3	4	5,2	7	10	13,5	21,5	26	30,5	61	96	157	215	255
Kg										50	70	120	175	200

ASTM A105

ASTM A 351 CF8M

- DATI E CARATTERISTICHE SOGGETTI A VARIAZIONI SENZA PREAVVISO
- SPECIFICATIONS SUBJECT TO MODIFICATIONS WITHOUT PRIOR NOTICE
- TOUS DROITS DE MODIFICATION RESERVES
- KONSTRUKTIONÄNDERUNGEN VORBEHALTEN



ADLER SpA - BALL VALVES  
 20010 S. STEFANO TICINO (MI) ITALY V.le BORLETTI, 14 Tel. +39/02974842.11 FAX +39/0297271698  
 E-mail: [adler@adlerspa.com](mailto:adler@adlerspa.com) <http://www.adlerspa.com>

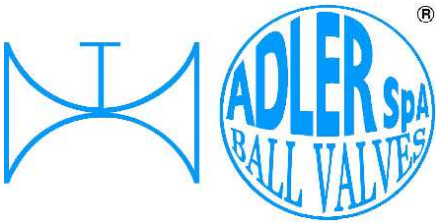

ISO 9001 by L.R.  
 PED DIR. 2014/68/UE by L.R.  
 ATEX DIR. 2014/34/UE by B.V.  
 FIRE SAFE EXECUTION BS6755/API 607 by L.R.  
 FIRE SAFE TESTED ISO 10497 by L.R.  
 ISO 15848 by TÜV  
 ANTISTATIC DEVICE by L.R.  
 EAC CERTIFICATION by B.V.

TYPE  
**FM2**  
 PN 10 ÷ 40

• ESECUZIONI • EXECUTIONS • EXECUTIONS • AUSFÜHRUNGEN



EXECUTION 4- 12

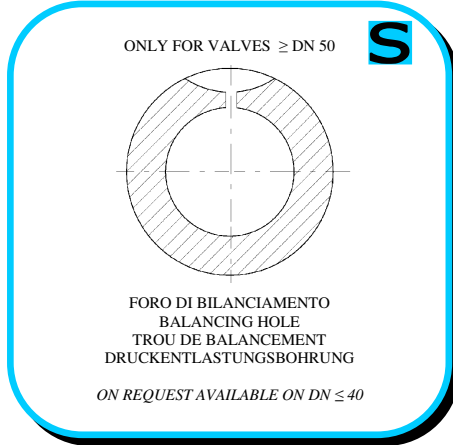

EXECUTION 6 - 16

**S** STANDARD

**O** OPTIONAL

**1** **S**

**CARBON STEEL**

ASTM A105  
 DN 15 ÷ 300

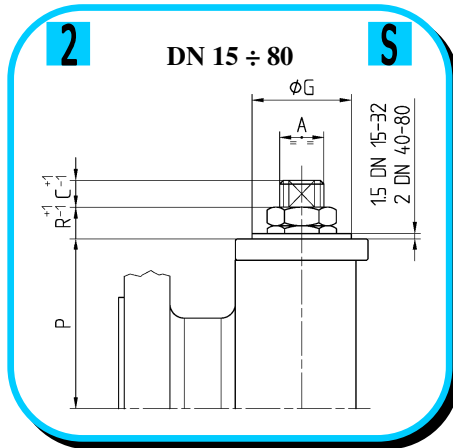

**3** **S**

**STAINLESS STEEL**  
 ASTM A479 316/316L  
 DN 15 ÷ 125

ASTM A351 CF8M  
 DN 150 ÷ 300

**4** **S**

-STELO ANTI ESPULSIONE -ANTI BLOW OUT STEM  
 -TIGE ANTIEXPULSION -AUSBLASGESICHERTE WELLE

-PACCO A "V" -CHEVRON RINGS  
 -JOINT A "V" -3 FACHE DACHMANSCHETE  
 ANTISTATIC DEVICE ANTISTATIK VORRICHTUNG  
 BS 5146

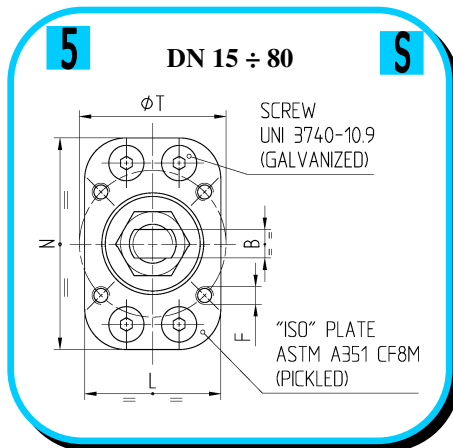

**6** **O**

BREVETTO - PATENTED  
 00219688 - 21-04-1993

FKM (VITON)

- "O" RING STELO "O" RING ON STEM  
 -TIGE AVEC "O" RING  
 -"O" RING IM SPINDELBEREICH



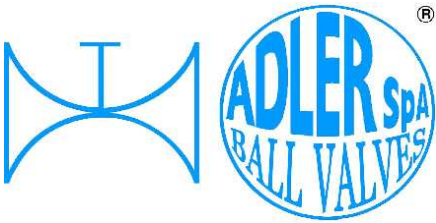

ISO 9001 by L.R.  
 PED DIR. 2014/68/UE by L.R.  
 ATEX DIR. 2014/34/UE by B.V.  
 FIRE SAFE EXECUTION BS6755/API 607 by L.R.  
 FIRE SAFE TESTED ISO 10497 by L.R.  
 ISO 15848 by TÜV  
 ANTISTATIC DEVICE by L.R.  
 EAC CERTIFICATION by B.V.

TYPE  
**FM2**  
 PN 10 ÷ 40

**7** **O**

-PROLUNGA STELO -STEM EXTENSION  
 -TIGE PROLONGEE -SPINDELVERLÄNGERUNG

**8** **O**

-PARTICOLARI INOX  
 -STAINLESS STEEL DETAILS  
 -ACCESSOIRES EN INOX  
 -EDELSTAHLTEILE

**9** **S**

-ATTACCO "ISO" -"ISO" CONNECTIONS  
 -SYSTEM "ISO" -ANSCHLUSS "ISO"

**GEAR BOX  
 AG series**

**11** **O**

-TENUTE INTEGRALE -POCKETLESS SEATS  
 -TENUCE INTEGRALE -TOTRAUMARM  
 -P.T.F.E. / R.T.F.E.

**12** **O**

FIRE SAFE  
 ISO 10497 "ISO-FT"  
 (BS 6755 / API 607)

**13** **S**

BREVETTO - PATENTED  
 00219619

-DOPPIA TENUTA -DOUBLE SEALS  
 -DOUBLE ETANCHEITE -DOPPELTE ABDICHTUNG  
 -LATERALE A BATTUTA -METAL BEATING END  
 -LATERAL AVEC BATTUE MECANIQUE  
 -METALLISCHER ANSCHLAG DES  
 GEGENGEHÄUSES

**14** **O**

VEDERE / SEE ANSI B16.34

FLUSSO  
 FLOW

-FORO DI SCARICO NELLA SFERA  
 -OVERPRESSURE HOLE INTO BALL  
 -TROU DECOMPRESSION DANS LA BOULE  
 -ENTLASTUNGSBOHRUNG IN DER KUGEL  
 VALVOLA MONO DIREZIONALE  
 MONO-DIRECTIONAL VALVE

**15** **O**

P.T.F.E./GRAPHITE  
 P.T.F.E.  
 100-250

-SERVIZIO CRIOGENICO - CRYOGENIC SERVICE  
 -SERVICE CRYOGENIQUE  
 -TIEFTEMPERATUR SERVICE

**16** **O**

-FIRE SAFE ISO FT+ "O" RING STELO  
 -FIRE SAFE ISO FT+ "O" RING ON STEM  
 -SECURITE FEU ISO FT+ TIGE AVEC "O" RING  
 -FEUERSICHERE AUSFÜHRUNG ISO FT+  
 "O" RING IM SPINDELBEREICH

**17** **O**

-TENUTA INTEGRALE METALLICA  
 -METALLIC POCKET LESS SEATS  
 -TENUCE INTEGRALE METALLIQUE  
 -TOTRAUMARM METALLISCH

**18** **O**

-SFERA CIECA PER CAMPIONATURA  
 -BLIND BALL FOR SAMPLING  
 -PRISE-ECHANTILLON  
 KUGEL FÜR PROBEAHME

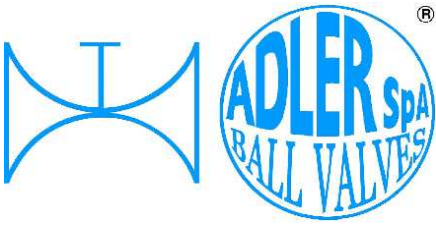

ISO 9001 by L.R.  
 PED DIR. 2014/68/UE by L.R.  
 ATEX DIR. 2014/34/UE by B.V.  
 FIRE SAFE EXECUTION BS6755/API 607 by L.R.  
 FIRE SAFE TESTED ISO 10497 by L.R.  
 ISO 15848 by TÜV  
 ANTISTATIC DEVICE by L.R.  
 EAC CERTIFICATION by B.V.

TYPE  
**FM2**  
 PN 10 ÷ 40

**DIMENSIONI FLANGE - FLANGE DIMENSION - DIMENSIONS BRIDES - FLANSCHANSCHLUSSMASSE**

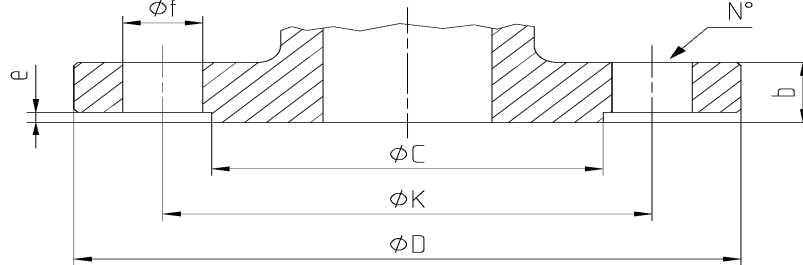

DN	Ref.	10	15	20	25	32	40	50	65	80	100	125	150	200	250	300
PN 10	D		95	105	115	140	150	165	185	200	220	250	285	340	395	445
	C		45	58	68	78	88	102	122	138	158	188	212	268	320	370
	K		65	75	85	100	110	125	145	160	180	210	240	295	350	400
	N°		4	4	4	4	4	4	4*	8	8	8	8	8	12	12
	f		14	14	14	18	18	18	18	18	18	18	22	22	22	22
	b		16	18	18	18	18	18	18	18	20	20	22	22	24	26
PN 16	D		95	105	115	140	150	165	185	200	220	250	285	340	405	460
	C		45	58	68	78	88	102	122	138	158	188	212	268	320	378
	K		65	75	85	100	110	125	145	160	180	210	240	295	355	410
	N°		4	4	4	4	4	4	4*	8	8	8	8	12	12	12
	F		14	14	14	18	18	18	18	18	18	18	22	22	26	26
	b		16	18	18	18	18	18	18	18	20	20	22	22	24	26
PN 25	D		95	105	115	140	150	165	185	200	235	270	300	360	425	485
	C		45	58	68	78	88	102	122	138	162	188	218	278	335	395
	K		65	75	85	100	110	125	145	160	190	220	250	310	370	430
	N°		4	4	4	4	4	4	8	8	8	8	8	12	12	16
	f		14	14	14	18	18	18	18	18	22	26	26	26	30	30
	b		16	18	18	18	18	20	22	24	24	26	28	30	32	34
PN 40	D		95	105	115	140	150	165	185	200	235	270	300	375	450	515
	C		45	58	68	78	88	102	122	138	162	188	218	285	345	410
	K		65	75	85	100	110	125	145	160	190	220	250	320	385	450
	N°		4	4	4	4	4	4	8	8	8	8	8	12	12	16
	f		14	14	14	18	18	18	18	18	22	26	26	30	33	33
	b		16	18	18	18	18	20	22	24	24	26	28	34	38	42
e		2	2	2	2	2	3	3	3	3	3	3	3	3	3	4

ADLER SALES DEPT.

