

General information

A routine maintenance or lubrication of the high performance butterfly valve is not necessary. Should a leakage occur at the gland packing, retighten the gland nut (20). Take care that the gland nut is not tightened too much. Normally the leakage can be stopped by simply turning the nut by a quarter.

Replacing the Gland Packing

If the leakage cannot be stopped using the above method, the gland packing must be replaced. For replacing the gland packing the valve needs not to be removed from the pipeline.

- Check whether the pipeline has been rendered depressurized and is empty.
- Remove the operating element.
- Loosen the fixing devices (18, 20) of the gland flange and lift off the gland flange (9).
- Remove the gland (8). A groove in the upper part of the gland makes the removal easier.
- Remove the packing rings (6) and thoroughly clean the packing area.
- Insert a new packing set, whereby it is to be ensured that the correct packing material is used.
- Insert the gland, place the gland flange on top and fix it using the screws and nuts. Tighten the nuts reciprocally so that the gland flange is not tilted. Only slightly tighten the nuts until the leakage is stopped.

Replacing the Seat

The valve must be taken out of the pipeline for replacing the seat.

- Ensure that the pipeline is rendered depressurized and is empty.
- Completely close the valve, loosen the flange screws and remove them so far that the valve can be taken out.
- Lay the valve down with the insert ring (7) facing upwards.
- Loosen the set screws (15a) or cylinder screws (15b) and remove the insert ring.
- Remove the old seat (4). Clean the body and insert ring in the area of the seat-engaging surface.
- Lateral screw connection (15a): Open the valve. Install the new seat with the insert ring. Screw in the set screws (15a) in such a way that the insert ring can be moved but not lifted out. Close the valve to centre the insert ring and the seat. Tighten the set screws reciprocally (fingertight fastening) to fix the insert ring.
- Axial screw connection (15b): Close the valve completely. Install the new seat with the insert ring and tighten the cylinder screws (15b) reciprocally.

Mounting of the Hand Lever

- Screw the stud bolt (22) into the body and put the washer (26) on it.
- Insert the clamping bolt (24) into the hand lever (21) in such a way that the slit in the clamping bolt is aligned with the square in the hand lever.
- Place the hand lever on the shaft (3). The hand lever must lie on top of the washer (26).
- Tighten the clamping bolt with nut (25), thus fixing the hand lever to the shaft.
- Close the valve and adjust the stop position using the screw (27). Secure the screw with a nut (28).
- Screw the star knob (23) onto the stud bolt. For operating the valve loosen the star knob and retighten afterwards.

Mounting of the MULTITOP mounting plate

- Place the mounting plate (29) on the body.
- Insert the spring dowel sleeves (30) through the mounting plate into the body. The slit in the split taper sleeve must be facing in the force direction (see arrow in the mounting drawing) to reach a rigid connection. Do not insert the mounting plate without using spring dowel sleeves as the transverse forces cannot be taken on by the screws.
- Insert the cylinder screws (31) and tighten them.
- If required, push the square adapter onto the shaft. If necessary, use the enclosed retaining ring to ensure that the square adapter will not slip off the shaft.

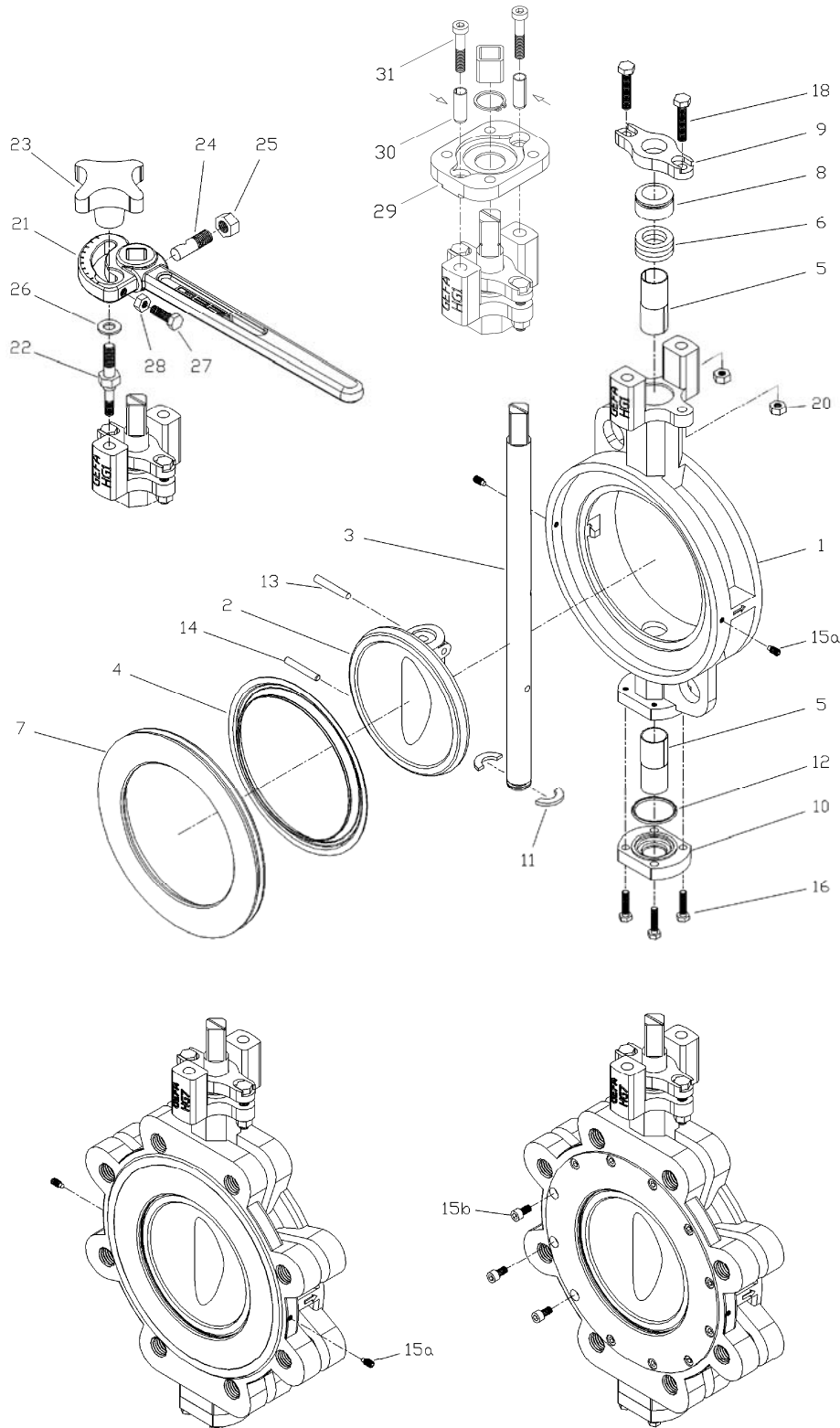

- | | | | |
|-----------------|--------------------------|------------------|------------------------|
| 1 Body | 9 Gland flange | 16 Hexagon screw | 26 Washer |
| 2 Disc | 10 Bottom flange | 18 Hexagon screw | 27 Hexagon screw |
| 3 Stem | 11 Axial securing device | 20 Hexagon nut | 28 Hexagon nut |
| 4 Seat | 12 Bottom flange seal | 21 Hand lever | 29 Mounting plate |
| 5 Bearing | 13 Tapered pin | 22 Stud bolt | 30 Spring dowel sleeve |
| 6 Gland packing | 14 Straight pin | 23 Star knob | 31 Cylinder screw |
| 7 Insert ring | 15a Set screw | 24 Clamping bolt | |
| 8 Gland | 15b Cylinder screw | 25 Hexagon nut | |