

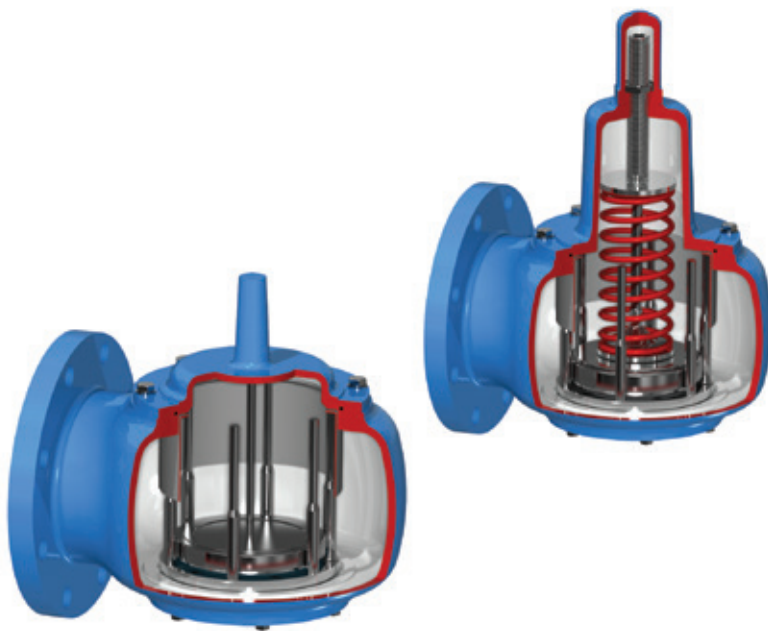

ANDERSON GREENWOOD TYPE 4410 SIDE ENTRY ATMOSPHERIC VACUUM RELIEF VALVES

Weight or spring loaded valves with a side inlet capable of high capacity vacuum relief. Designed to work closer to a tank's MAWW, increasing productivity, reducing emissions and product evaporation



FEATURES

- Increased flow capacities reduce the required valve size and the corresponding connections and piping costs.
- Fully open at 10% overpressure, enabling setting close to MAWW and minimizing tank emissions.
- Large body for increased capacity providing high flow performance for full conformance to API2000/ISO28300.
- Leakage rate of 0.5 scfh (0.015 Nm³ /hr) or less at 90% of setpoint.
- Weight or spring loaded models available.
- Choice of body materials.
- Modular design enables all components to be removed and replaced in-situ for quicker, simpler maintenance.
- Optional 'all-weather' coating prevents frozen condensate build-up and sticking of vital components in cold weather applications.

GENERAL APPLICATION

Type 4410 valves allow tanks to work closer to their MAWW thus increasing productivity, reducing emissions and product evaporation. Increased flow capacities reduce the valve's size, corresponding connections and piping costs in applications for storage tank farms, oil and gas production, the petroleum, pharmaceutical and chemical sectors.

TECHNICAL DATA

| | |
|-----------------|-----------------------------------------|
| Materials: | Aluminum, carbon steel, stainless steel |
| Sizes: | 3" to 14" (DN 80 to 350) |
| Vacuum settings | |
| Weight loaded: | up to -1.5 psig (-100 mbarg) |
| Spring loaded: | up to -15 psig (-1 barg) |
| Certification: | ATEX 94/9 EC |

ANDERSON GREENWOOD TYPE 4410 SIDE ENTRY ATMOSPHERIC VACUUM RELIEF VALVES

MODELS OVERVIEW

Type 4410 valves are high capacity, full lift vacuum relief valves designed for use on atmospheric and low pressure storage tanks. Their primary function is to protect the tank from physical damage or permanent deformation caused by increases in vacuum encountered in normal operations.

The valves are fully open at 10% overpressure allowing the user to have a quicker acting valve that can be set closer to the tank's maximum allowable working vacuum, reducing emission losses.

There are two model variants:

Model 4410H offers weight-loaded vacuum relief.

Model 4410HV, spring-loaded vacuum relief.

APPLICATION

By controlling tank venting, Type 4410 vacuum valves not only minimize emissions to the environment but also the loss of product to evaporation. Their 'air-cushion' seating design keeps the valve sealed tightly until the vacuum inside the tank approaches the valve setting. The larger body allows for greater vacuum capacity in accordance with the most recent versions of tank vents sizing standards (API 2000/ISO 28300).

They offer the option of a non-frosting and icing-resistant coating on the pallet perimeter, stem, guide posts and seats which, along with the flexible PTFE seat insert, provides additional protection against pallets freezing closed.

TESTING

Each valve is tested for proper setting, for a leakage rate of less than 0.5 scfh (0.015 Nm³/hr) of air at 90% of the set point and for leak tightness at 75% of set point as required in API standard 2000.

SPECIFICATIONS

Available materials

- Aluminum with aluminum or stainless steel trim
- Carbon steel with stainless steel trim
- Stainless steel with stainless steel trim
- Special materials on application

Sizes, inches (DN)

- 3" (80)
- 4" (100)
- 6" (150)
- 8" (200)
- 10" (250)
- 12" (300)
- 14" (350)

Flanged connections –standard flange drilling

Aluminum body

Drilled to ANSI Class 150 dimensions (flat face)

Drilled to DIN 2633 (PN 16) dimensions (flat face)

CS and SS body

Drilled to ANSI Class 150 dimensions

(raised or flat face)

Drilled to Imperial DIN 2633 (PN 16) dimensions

(raised or flat face)

Options

- PTFE coated trim to minimize ice build-up
- Stainless steel weights
- Steam jackets
- Proximity sensors to monitor valve opening and closing

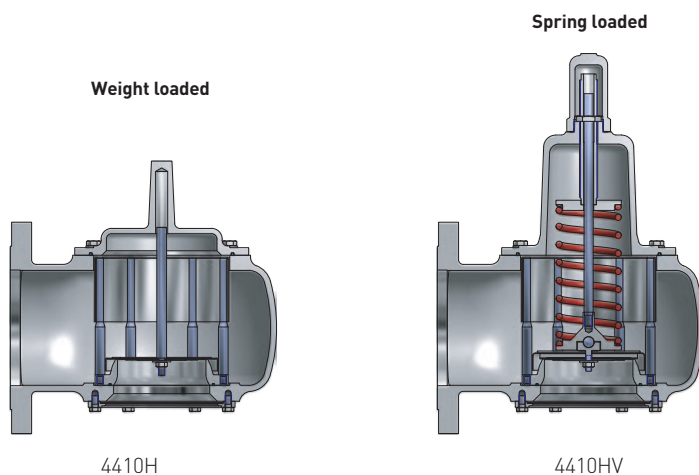

ANDERSON GREENWOOD TYPE 4410 SIDE ENTRY ATMOSPHERIC VACUUM RELIEF VALVES

DIMENSIONS (mm)

4410H

| Size | | A | B | C | D |
|--------|-----|-----|-----|-----|-----|
| Inches | DN | | | | |
| 3 | 80 | 253 | 153 | 252 | 79 |
| 4 | 100 | 323 | 193 | 293 | 91 |
| 6 | 150 | 352 | 200 | 331 | 111 |
| 8 | 200 | 435 | 245 | 442 | 148 |
| 10 | 250 | 592 | 330 | 552 | 181 |
| 12 | 300 | 730 | 410 | 639 | 207 |
| 14 | 350 | 854 | 480 | 426 | 230 |

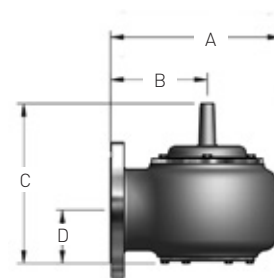

4410H

4410HV

| Size | | A | B | C | D |
|--------|-----|-----|-----|------|-----|
| Inches | DN | | | | |
| 3 | 80 | 253 | 153 | 374 | 79 |
| 4 | 100 | 323 | 193 | 418 | 90 |
| 6 | 150 | 352 | 200 | 473 | 111 |
| 8 | 200 | 435 | 245 | 681 | 148 |
| 10 | 250 | 592 | 330 | 883 | 181 |
| 12 | 300 | 730 | 410 | 1083 | 207 |
| 14 | 350 | 854 | 480 | 1266 | 230 |

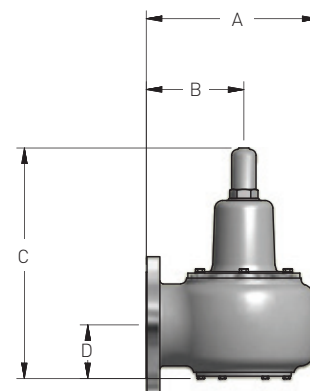

4410HV

ANDERSON GREENWOOD TYPE 4410 SIDE ENTRY ATMOSPHERIC VACUUM RELIEF VALVES

SIZING

API 2000 - valve sizing (air)

Once the required air venting rates have been determined using data from the following pages or supplied by the customer, a calculation should be conducted to determine the required valve discharge area using the formula below. Once this area has been determined, select the first standard valve flow area above this.

Metric units:

$$A = \frac{R F_o}{12515 \times (P_{10} + At) \times K_{d0} \times F_o} \sqrt{\frac{K}{M \times T \times Z (K-1)} \left[\left(\frac{P_2 + At}{P_{10} + At} \right)^{\frac{2}{K}} - \left(\frac{P_2 + At}{P_{10} + At} \right)^{\frac{K+1}{K}} \right]}$$

Where:

| | |
|-----------------------------------------------------------------------------------------|------------------------|
| VR = Air venting requirements | Nm ³ /h Air |
| A = Required flow area of valve | cm ² |
| Kd = Coefficient of discharge (see page 7) | |
| P ₁ = Inlet flowing pressure (Set + over pressure – inlet pressure loss)* | Barg |
| P ₂ = Outlet pressure (Back pressure) | Barg |
| K = Ratio of specific heats Air = 1.4 | |
| T = Temperature at valve inlet | 273 deg K |
| M = Molecular weight | Air = 28.97 |
| Z = Compressibility factor | Air = 1.0 |
| At = Atmospheric pressure | 1.013 bar |
| F = Over pressure factor (Use 1 for Type 4410 valves) | |

* The inlet pressure loss is due to factors such as difficult inlet piping, flame arresters, etc. and must be less than overpressure.

ANDERSON GREENWOOD TYPE 4410 SIDE ENTRY ATMOSPHERIC VACUUM RELIEF VALVES

SIZING

TABLE OF FLOW COEFFICIENTS (Kd) - MODEL 4410H

| Size | | Flow area (cm ²) | API connection |
|--------|-----|---------------------------------|----------------|
| Inches | DN | | Vacuum |
| 3 | 80 | 27.342 | 0.619 |
| 4 | 100 | 62.110 | 0.619 |
| 6 | 150 | 107.509 | 0.619 |
| 8 | 200 | 243.283 | 0.619 |
| 10 | 250 | 430.051 | 0.499 |
| 12 | 300 | 674.257 | 0.429 |
| 14 | 350 | 967.611 | 0.405 |

MINIMUM SET PRESSURES – WEIGHT LOADED

| Size | | Aluminum | | | Stainless steel | | |
|--------|-----|------------|------------|------------|-----------------|------------|------------|
| Inches | DN | V mbarg | L mbarg | H mbarg | V mbarg | L mbarg | H mbarg |
| 3 | 80 | 1.04 | 2.42 | 4.87 | 2.38 | 5.91 | 9.70 |
| 4 | 100 | 0.84 | 1.74 | 4.36 | 1.84 | 3.98 | 8.46 |
| 6 | 150 | 0.90 | 1.64 | 4.48 | 1.93 | 3.63 | 8.90 |
| 8 | 200 | 0.96 | 1.60 | 6.33 | 1.92 | 3.90 | 13.37 |
| 10 | 250 | 1.10 | 1.30 | 13.00 | 2.50 | 3.80 | 20.00 |
| 12 | 300 | 1.10 | 1.20 | 14.00 | 2.50 | 3.50 | 22.00 |
| 14 | 350 | 1.10 | 1.20 | 14.00 | 2.50 | 3.20 | 24.00 |

NOTE

V = very low pressure pallet

L = low pressure pallet

H = high pressure pallet

MINIMUM SET PRESSURES – SPRING LOADED

| Size | | Aluminum | | | | Stainless steel | | | |
|--------|-----|------------|------------|------------|-----------------|-----------------|------------|------------|-----------------|
| Inches | DN | V mbarg | L mbarg | H mbarg | Spring mbarg | V mbarg | L mbarg | H mbarg | Spring mbarg |
| 3 | 80 | 1.04 | 2.42 | 4.87 | N/A | 2.38 | 5.91 | 9.70 | 70 |
| 4 | 100 | 0.84 | 1.74 | 4.36 | N/A | 1.84 | 3.98 | 8.46 | 70 |
| 6 | 150 | 0.90 | 1.64 | 4.48 | N/A | 1.93 | 3.63 | 8.90 | 70 |
| 8 | 200 | 0.96 | 1.60 | 6.33 | N/A | 1.92 | 3.90 | 13.37 | 70 |
| 10 | 250 | 1.10 | 1.30 | 13.00 | N/A | 2.50 | 3.80 | 20.00 | 70 |
| 12 | 300 | 1.10 | 1.20 | 14.00 | N/A | 2.50 | 3.50 | 22.00 | 70 |
| 14 | 350 | 1.10 | 1.20 | 14.00 | N/A | 2.50 | 3.20 | 24.00 | 70 |

NOTE

V = very low pressure pallet

L = low pressure pallet

H = high pressure pallet

ANDERSON GREENWOOD TYPE 4410 SIDE ENTRY ATMOSPHERIC VACUUM RELIEF VALVES

FLOW CAPACITIES

API 2000 connection

API connection testing requires a square-edge flange connection for capacity publishing. This setup mimics a typical tank connection with its inherent pressure drop/capacity.

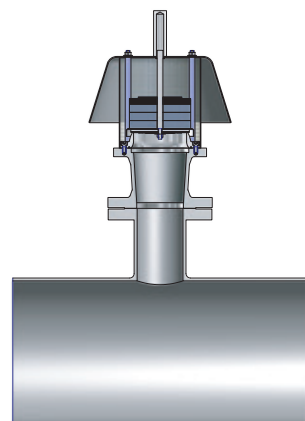

4410H
(ISO/API connection)

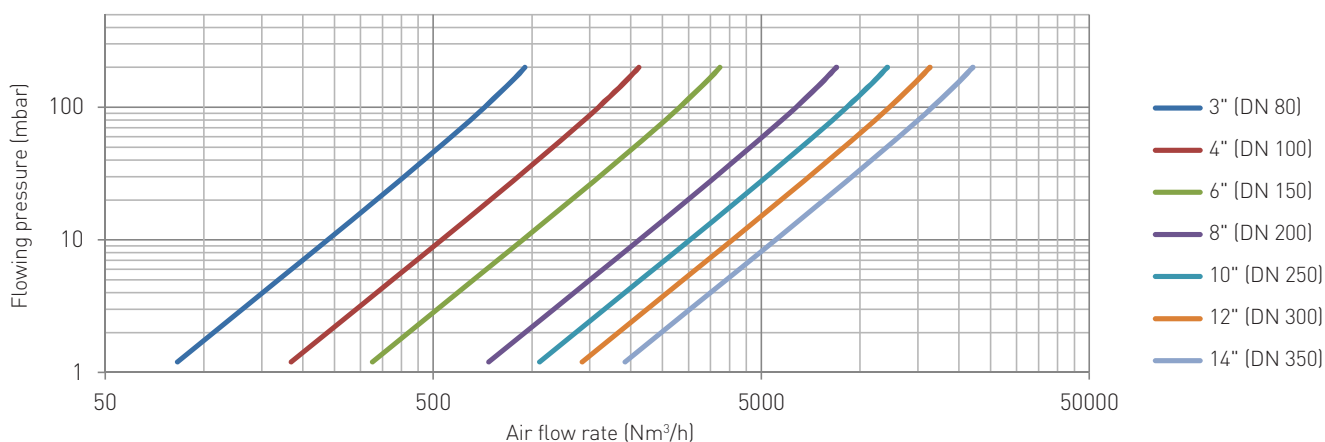

4410HV
(ISO/API connection)

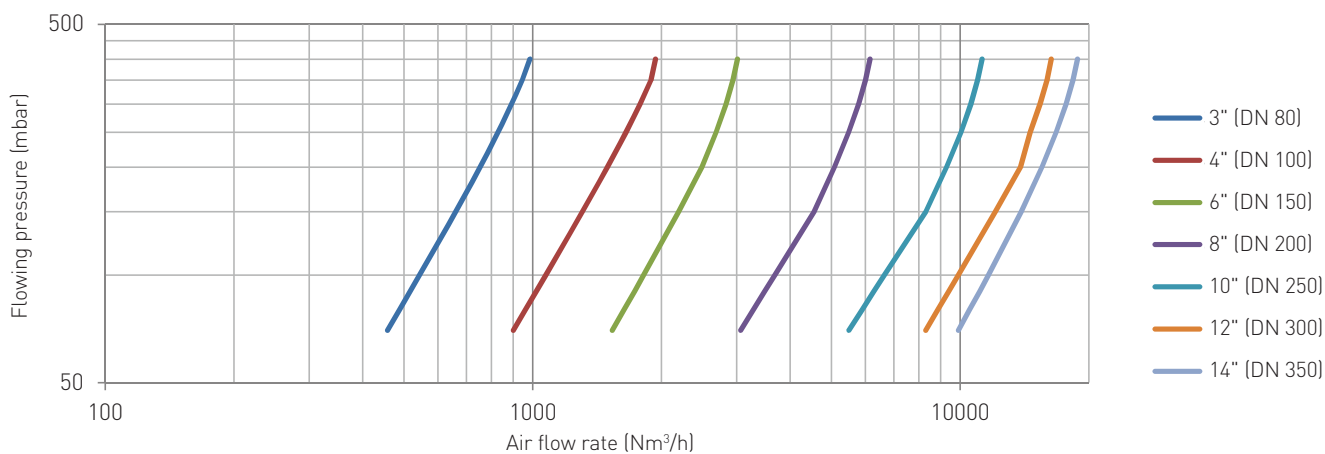

ANDERSON GREENWOOD TYPE 4410 SIDE ENTRY ATMOSPHERIC VACUUM RELIEF VALVES

FLOW CAPACITIES

Conical reducer

A conical reducer reduces the flow losses associated with the tank connection, providing the more accurate representation of pure valve performance. With this capacity, users can calculate their own tank connection losses and apply it to the valve flow.

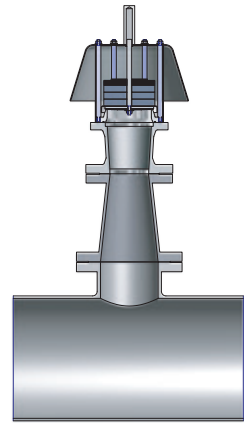

4410H
(Conical reducer)

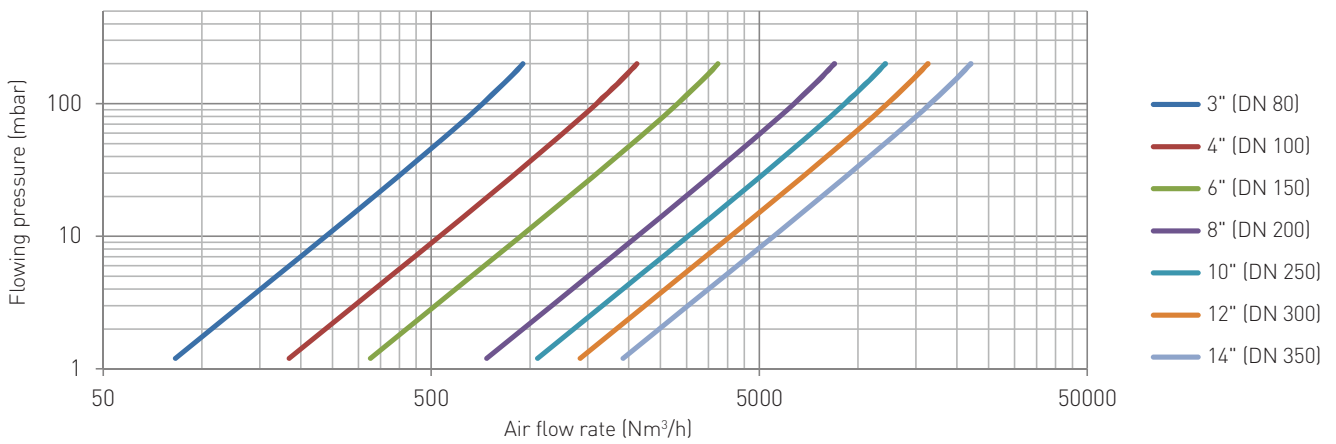

4410HV
(Conical reducer)

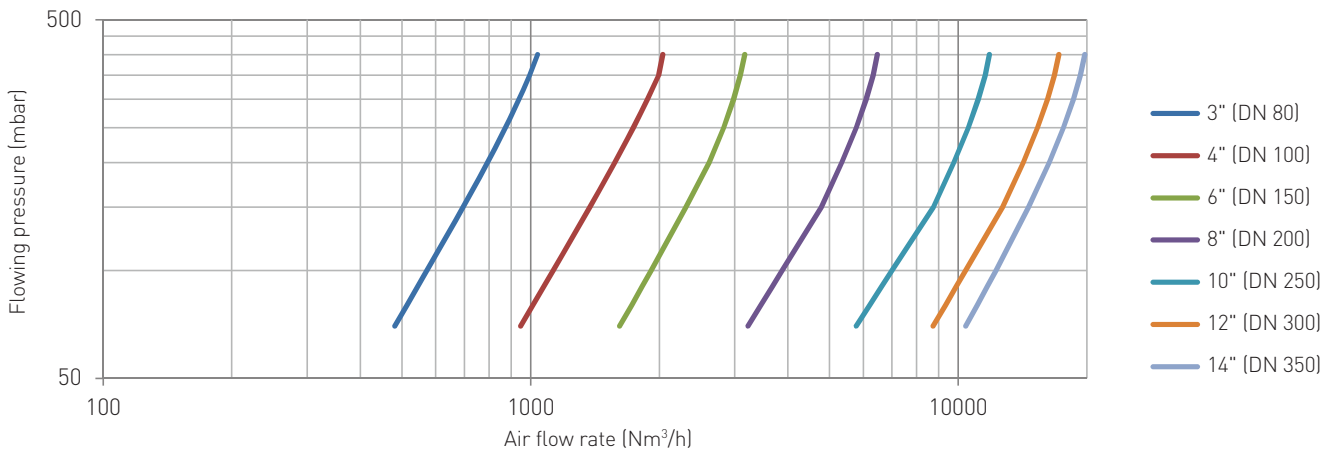

ANDERSON GREENWOOD TYPE 4410 SIDE ENTRY ATMOSPHERIC VACUUM RELIEF VALVES

SELECTION GUIDE

| Example: | 4410H | 04 | H | 1 | 1 | S | T | F | F | B | N |
|-----------------------------------------------------------|-------|--------------|----------------------------------|---------------|------------------------|---------------|---|---|---|---|---|
| Model | | | | | | | | | | | |
| 4410H | | | | | | | | | | | |
| 4410HV | | | | | | | | | | | |
| Tank connection | | | | | | | | | | | |
| 03 3" | | 06 6" | | 10 10" | | 14 14" | | | | | |
| 04 4" | | 08 8" | | 12 12" | | | | | | | |
| Vacuum load | | | | | | | | | | | |
| V Weight loaded – very low pressure pallet | | | | | | | | | | | |
| L Weight loaded – low pressure pallet | | | | | | | | | | | |
| H Weight loaded – high pressure pallet | | | | | | | | | | | |
| O Not applicable | | | | | | | | | | | |
| Body material | | | | | | | | | | | |
| 1 Aluminum | | | | | | | | | | | |
| 3 Carbon steel | | | | | | | | | | | |
| 5 316 Stainless steel (CF8M) | | | | | | | | | | | |
| 7 316L Stainless steel (CF3M) | | | | | | | | | | | |
| Trim (pallet/seat) | | | | | | | | | | | |
| 1 AL pallets/AL seat | | | | | | | | | | | |
| 2 316SS pallets/316SS seat | | | | | | | | | | | |
| 3 316LSS pallets/316LSS seat | | | | | | | | | | | |
| All-weather code | | | | | | | | | | | |
| S Standard, no coating | | | | | | | | | | | |
| W PTFE coated winterization | | | | | | | | | | | |
| Insert | | | | | | | | | | | |
| T Carbon impregnated PTFE (standard for HP pallet) | | | | | | | | | | | |
| B PFA (standard for VLP and LP pallet) | | | | | | | | | | | |
| V FKM | | | | | | | | | | | |
| Flange drilling | | | | | | | | | | | |
| F ANSI 150 for imperial studs | | | | | | | | | | | |
| 0 DIN PN10 for metric studs | | | | | | | | | | | |
| 6 DIN PN16 for metric studs | | | | | | | | | | | |
| Flange face | | | | | | | | | | | |
| F Flat face | | | | | | | | | | | |
| R Raised face (not available for aluminum bodies) | | | | | | | | | | | |
| Soft Goods | | | | | | | | | | | |
| B Nitrile/NBR (standard) | | | | | | | | | | | |
| T PTFE | | | | | | | | | | | |
| V FKM | | | | | | | | | | | |
| Options | | | | | | | | | | | |
| N None (standard) | | | S Stainless steel weights | | J Steam jackets | | | | | | |
| A Proximity switch | | | H Purge holes | | | | | | | | |

Neither Emerson, Emerson Automation Solutions, nor any of their affiliated entities assumes responsibility for the selection, use or maintenance of any product. Responsibility for proper selection, use, and maintenance of any product remains solely with the purchaser and end user.

Anderson Greenwood is a mark owned by one of the companies in the Emerson Automation Solutions business unit of Emerson Electric Co. Emerson Automation Solutions, Emerson and the Emerson logo are trademarks and service marks of Emerson Electric Co. All other marks are the property of their respective owners.

The contents of this publication are presented for informational purposes only, and while every effort has been made to ensure their accuracy, they are not to be construed as warranties or guarantees, express or implied, regarding the products or services described herein or their use or applicability. All sales are governed by our terms and conditions, which are available upon request. We reserve the right to modify or improve the designs or specifications of such products at any time without notice.